





# Sorting and palletizing of 4-bottle packs through a heated shrink-wrap system for small businesses

Martin Larrea, Eng.<sup>1</sup>, Faruk Abedrabbo, PhD.<sup>1</sup>, Cristhian Rueda, M.Sc.<sup>1,2</sup>, and Marcelo Moya, M.Sc.<sup>1</sup>

<sup>1</sup> Faculty of Technical Sciences, International University of Ecuador UIDE, Quito 170411, Ecuador, kagarzonzu@uide.edu.ec, anabedrabboha@uide.edu.ec, anquitoca@uide.edu.ec, mmoya@uide.edu.ec.

<sup>2</sup> Faculty of Engineering and Industries, UTE University, Quito 170129, Ecuador, andres.rueda@ute.edu.ec.

**Abstract**— *In Latin America, several businesses were established during the COVID-19 pandemic, which involved the process of packaging and distributing beverages. However, with the normalization of society and the increasing competition in the global market, the survival of these businesses is at risk. To ensure their competitiveness and reduce production costs, it is necessary to improve their processes. Small businesses face challenges in sorting, packaging, and palletizing filled bottles, a critical process usually carried out manually, increasing production costs and time. Therefore, to create more competitive businesses, this work proposes a semiautomatic sorting and palletizing system tailored for small or artisanal businesses. The paper provides a detailed overview of the mechatronic design, including selecting materials, motors, controllers, and sensors. It also explains the step-by-step process for controlling servomotors and sensors, the system's programming, and control. The machine's functionality was probed through ordering sequence and heating tests. With these experiments, the machine was improved to achieve 100% accuracy in sorting bottles and 90% in palletizing the 4-bottle packs.*

**Keywords**—palletizing, filled bottles, mechatronic design.

## I. INTRODUCTION

Small beverage plants and distributors often face a competitive disadvantage due to the lack of advanced machinery commonly available to more extensive companies with higher capital. This disparity limits their operational efficiency and negatively impacts their revenue. Hence, this proposal aims to design and construct a prototype machine exclusively for the grouping and packaging plastic bottles to bolster efficiency and competitiveness for small-scale operators in the sector.

Recent innovations have underscored the importance of automating industrial packaging processes. Ref. [1] introduced an automated pallet packaging system in 2021 that adapts to various product types, suggesting substantial gains in operational efficiency. However, the industrial current packaging machines are semi-automatic and require substantial manual input, increasing time and resource consumption and reducing productivity [2]. High-industry-level machines are more advanced but are expensive and complex, making them unsuitable for small-scale operations.

Ref. [3] proposed a less complex yet effective system using a rotating platform for pallet wrapping. This system simplifies the packaging process while maintaining effectiveness. Ref. [4] designed a semi-automatic machine utilizing a stretch film plastic gripping system to enhance product safety and quality during transportation. Additionally, Ref. [5] explored the development of an industrial-purpose robotic arm that proposes an axial arm plan, signifying a shift toward task-specific automation solutions in industrial settings. Ref. [6] developed a 3-degree-of-freedom Cartesian robot for educational purposes, emphasizing the importance of hands-on learning in robotics. Ref. [7] demonstrated the adaptability of microcontrollers to complex control tasks in automated systems. At the same time, Ref. [8] illustrated the potential of combining advanced control systems with practical applications in environmental management.

Ref. [9] also developed a packing system based on the coordinate robot for plastic bottles, which performs automatic sorting, laying, and packing. Although the process is entirely automated, the machine packs the bottles in cardboard boxes and does not palletize them with shrink film. Similarly, Ref. [10] proposed an automatic system of packaging bottles using sensors and actuators, which was affordable to small industries to increase efficiency. The developed system eliminated the need for workers and presented low cost and maintenance. However, the machine packed the bottles independently in slots and could not produce a palletizing process.

Other work proposed a robotized palletizer that includes a Human-Machine Interface, a PLC program, and a servo system [11]. This integration allowed the robot to handle several boxes simultaneously to produce high-speed palletizing. In the same way, a mobile robotized system for logistics applications was also tested [12]. This robot can extract items from homogeneous pallets and assemble new pallets with heterogeneous goods. Nonetheless, these palletizing robots focus more on ordering boxes than bottles.

Ref. [13] have highlighted that shrink wrapping systems can also label bottles or packages, improving the aesthetics of the company's products and marketing. On the other hand, the idea that shrinking wrapping systems enable extra protection for glass bottles was also analyzed [14]. Although this protection does not prevent the bottles from breaking, it does

**Digital Object Identifier:** (only for full papers, inserted by LACCEI).  
**ISSN, ISBN:** (to be inserted by LACCEI).  
**DO NOT REMOVE**

prevent their contents from spilling, which can be helpful in pharmacological applications.

Through these studies, it is evident that industrial automation and robotics are evolving rapidly, with a clear trend towards enhancing efficiency, safety, and environmental sustainability. These advancements, from automated packaging systems to sophisticated control mechanisms, contribute to operational improvements, and offer significant educational value, laying the groundwork for future innovations. However, As seen in the literature, most of these processes are designed for packaging bottles in boxes or palletizing these boxes. These are usually applications for mass-consumption companies with huge volumes.

The proposed semi-automatic bottle sorting and palletizing machine presents advantages and challenges for small businesses, a market perhaps forgotten by large packaging companies because the design and size of the machine may not represent a significant profit. Similarly, small businesses' labor is limited since the same operator must perform several tasks. In this way, presenting a machine in which part of a process can be automated frees up labor, allowing this operator to dedicate himself to other tasks, thus increasing his production.

Integrating a semi-automatic design into the operations of small distributors will substantially enhance their operational efficiency and flexibility, outperforming traditional manual methods. The semi-automatic machine promises a safer working environment. It supports high-quality product packaging and transportation, highlighting the critical role of automation in the familiar and artisanal commerce of beverages.

## II. DESIGN

Addressing the unique challenges of small-scale distributors, developing the semi-automatic bottle sorting and palletizing machine represents a critical step towards operational efficiency and competitive parity in the beverage industry. This section outlines the comprehensive design process that has been undertaken to ensure that the machine meets the nuanced needs of these operations.

At the heart of the prototype is an intricate design that seamlessly integrates mechanical, electronic, and control systems following the mechatronic methodology described in Refs. [15, 16]. This integration not only facilitates the machine's smooth operation but also exemplifies the principles of mechatronics. As depicted in Fig. 1, the machine's 3D architecture is a testament to carefully considering each component's role and the overall system's synergy.

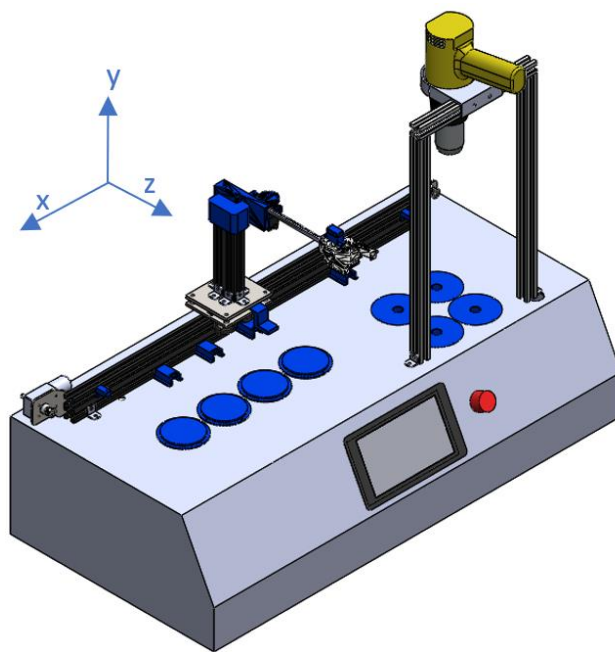

Fig. 1: 3D CAD developed for the sorting and palletizing machine.

### I. Mechanical Design

Developing the semi-automatic bottle sorting and palletizing machine's mechanical structure was a careful blend of materials chosen for their durability, lightweight, and precision capabilities. This combination results in a robust and agile prototype suitable for the precise task of packaging plastic bottles. The machine's foundation was constructed from steel, chosen for its durability, providing a stable base that ensures longevity. An aluminum frame was utilized to balance strength with minimal weight, optimizing the machine's maneuverability without compromising stability. For components that required intricate design, such as the gripper mechanism, 3D printing technology offered the necessary precision and efficiency, allowing for creating detailed parts with complex geometries.

Dimensional accuracy was paramount in the machine's design, which was tailored to efficiently group and package four 500ml bottles. The base's compact design accommodated essential functions within a minimal footprint, including storage, filling areas, and the axial robot's movement pathways. The selection of A-36 steel for the base was concluded after evaluating various materials, prioritizing industrial-grade durability, machinability, and cost-effectiveness, thus outperforming alternatives such as stainless steel or wood.

Integrating specific mechanical and electronic components was crucial for the prototype's functionality. The engineering of these elements demands precision machining

and assembly, emphasizing the significance of mechanical design. Central to the machine's operation, the axial robot featured prismatic joints that provided two degrees of freedom, facilitating efficient bottle handling. A belt and pulley system enabled x-axis movement. At the same time, a pinion and rack mechanism were employed for z-axis motion, exemplifying the application of mechanical engineering principles in achieving innovative and efficient design solutions.

The axial robot's design and functionality were meticulously planned to ensure precise and efficient bottle transfer. Utilizing V20x40 aluminum profiles, the design prioritized lightweight construction and ease of assembly. The x-axis movement was facilitated by a rubber-toothed belt and pulley system, with one pulley attached to the motor shaft and another at the profile's end. The robot's base, crafted from A36 steel, underwent CNC machining to ensure precise attachment points and smooth operation along the aluminum profile.

For vertical movement and gripper operation, a pinion with a 30 mm radius and 30 teeth paired with a rack measuring 150 mm in length was manufactured and implemented. 3D printing was strategically employed for manufacturing components such as the pin, zipper, and gripper, allowing for custom designs that met the specific requirements of the machine. The G-code generation for these parts was carefully tailored to balance strength and material efficiency, ensuring that load-bearing components were robust. In contrast, non-structural parts were optimized for weight reduction.

## II. Electronic Design

The electronic subsystem of the machine was a critical component that ensured the precise and efficient operation of the mechanical mechanisms. In this section, the electronic parameters, including power supply, controllers, Human-Machine Interface (HMI), modules, motors, and other essential components, were selected. The connections of these elements are depicted in the electronic block diagram of Fig. 2.

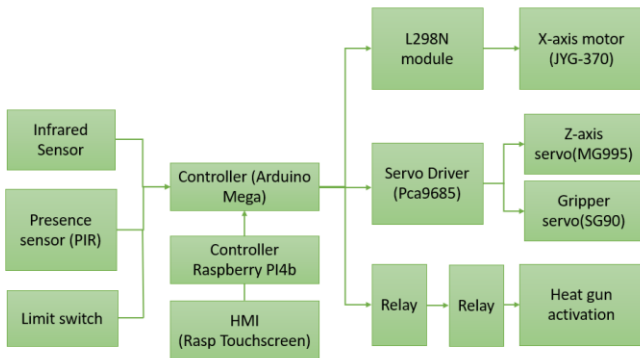

Fig. 2: Electronic block diagram for the machine developed.

### B.1. Controller Selection

The controller selection is pivotal to the system's functionality, balancing cost-effectiveness, connectivity, programmability, and the adequacy of inputs and outputs. An exhaustive evaluation led to the choice of the Arduino Mega due to its comprehensive feature set, satisfying the system's diverse requirements as outlined in Table I.

TABLE I  
DETAIL OF INPUTS AND OUTPUTS TO CONTROL THE MACHINE

Input Element	Quantity	Type
Infrared sensor	4	Digital
Presence Sensor	4	Digital
Motor encoder	2	Digital
Limit switch	2	Digital
Output Element	Quantity	Type
L298 Module	3	Digital (1 PWM)
Servo driver	2	SDA and SCL
Heat gun relay	1	Digital
HMI	1	DSI Port

### B.2. Touchscreen For HMI

The project incorporated a touch screen and a Raspberry Pi4 for the interface, facilitating communication between the user and the machine. Thonny, a Python language inside the Raspberry Pi, was used to program the interface code. Serial communication with the Arduino MEGA, which controls sensors and actuators, was also established.

### B.3. Motors Selection

To move the robot along the x-axis effectively, a DC motor with a torque exceeding 0.03 Nm was deemed necessary. The chosen motor, JY-370, operates at a speed of 40 rpm, a rate that ensures the cart moves at a functional pace. However, this speed can be adjusted upwards to accommodate the torque demands imposed by the robot's weight, ensuring optimal performance. Mechanically, the robot's vertical (z-axis) movement was facilitated by two servomotors, which engage a rack and pinion mechanism for precise control. For the z-axis movement, a continuous rotation servomotor, capable of exceeding 360 degrees of rotation, was required. The MG995 servomotor was selected for this task, given its ability to meet the extensive range of movement needed.

The operation of the gripper mechanism was driven by the MG90s Micro Servo, which features a durable metal casing. This servo was specifically chosen for its ability to execute a 30-degree movement to open the gripper and securely hold the bottles, showcasing a tailored approach to component selection for optimized system functionality.

### B.4. Motor Drivers

To implement and handle the two different motor types, two distinct drivers were required. For powering the DC motor

and controlling its direction, the L298N was utilized. This driver enabled the motor supply with the required 12V for achieving maximum speed and provided the flexibility to vary the speed using a PWM pin. However, it was not necessary in this case. For the servomotors, the PCA-9685 module was employed as a specialized driver. This choice was made to circumvent the Arduino's control issues and segregate the servo power supply from other components. This module facilitated the control of two servos through SDA and SCL communication channels, ensuring effective and independent servo management.

### B.5. Sensors

Three different sensors played crucial roles in various stages of the process. Infrared sensors and limit switches were employed to guide the robot's movement along the axis, ensuring precise positioning. Concurrently, a presence sensor served as a verification method for detecting the presence of bottles in the system. Four infrared sensors were utilized to determine and regulate the robot's position along the axis. This configuration ensured the motor would halt once the robot reached each required position. Additionally, limit switches were employed to define the physical boundaries of the robot's movement. While a mechanical stop could have been an alternative, limit switches provided a practical solution for halting the motor at specific points.

Additionally, presence sensors (Micro sensor PIR) were used at each bottle base in the packing area to confirm that the bottle reached the required position for packing. This verification allowed us to know if there was any error during the process and to stop it once a bottle had not reached its desired position.

### B.6. Heat Gun and Relays

To facilitate the packaging process, an 1800W heat gun with adjustable temperature settings was employed. The heat gun was activated using two relays: a 12V-5A DC relay and a 40A solid-state relay (SSR-40A). These relays were crucial in efficiently controlling and powering the heat gun for the desired temperature and packaging outcomes. The initial 5A relay, linked to the controller, facilitated the passage of the required voltage to activate the solid-state relay. The solid-state relay, in turn, was responsible for being in the line of the heat gun, managing its activation or deactivation as needed.

### B.7. Emergency Button

Including an LA-38 push button provided a rapid response mechanism for emergency stop or system reset, enhancing the machine's safety and user control.

### B.8. Power Supply Selection

A detailed evaluation of each component's power requirements was developed to select a 12V – 10A power supply, ensuring sufficient capacity and a safety margin for reliable operation. Table II shows the amount of current and voltage that each electronic component needs.

TABLE II  
AMOUNT OF CURRENT PER ELECTRONIC COMPONENT

Component	Quantity	Total Current, A	Total Voltage, V
Raspberry	1	2.5	5
HMI	1	0.1	3.3
Arduino Mega	1	0.09	5
JYG-370	1	1.5	12
L298N	1	0.036	12
MG995	1	0.5	4.8
SG90	1	0.2	4.8
Infrared Sensor	4	0.005	3
PIR Sensor	4	0.005	2.7
Relay	1	0.07	5
<b>Total</b>	-	<b>5.02</b>	<b>12</b>

### B.9. Step down

The LM2595 step-down converter was employed to adjust the voltage for components requiring less than 12V, illustrating the thoughtful consideration of component compatibility and power management.

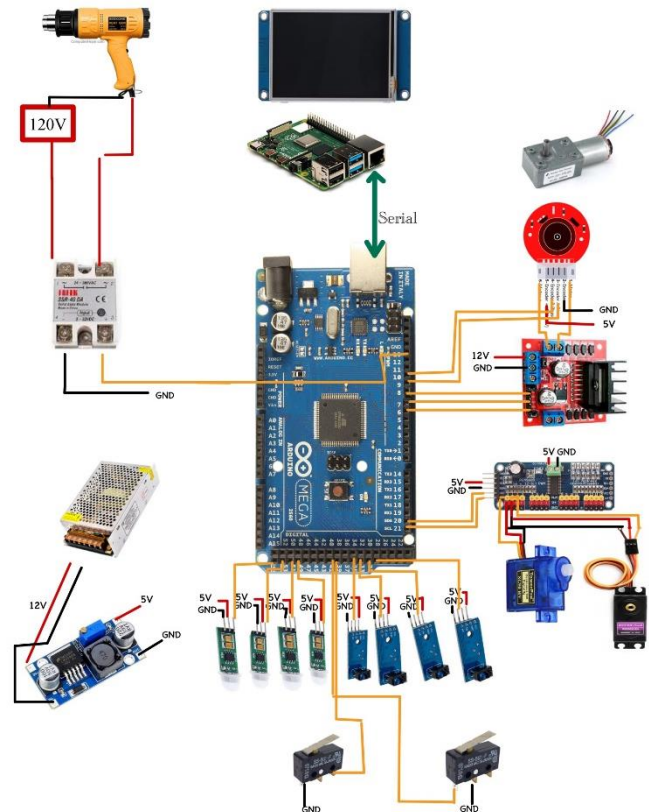

Fig. 3: Electronic connection diagram sorting and palletizing machine.



To complete the electronic design, all previously described components were implemented according to the diagram in Fig. 3. All these components were carefully installed on the machine. To avoid mishandling or damage to the electrical components, most of them were installed inside the machine's frame, except for the actuators and sensors installed at key points for the correct operation of the machine. The interface screen was installed on the frame at the front so that it is easy for the machine operator to access it.

### III. Programming and Control

The control system of the semi-automatic bottle sorting and palletizing machine was orchestrated through a dual-language programming approach, utilizing distinct environments to manage both the machine's core operations and its interface. The Arduino's operational sequence was programmed in C, offering robust control over the machine's hardware components. Concurrently, MicroPython within Thonny's IDLE on the Raspberry Pi was utilized for the interface development, facilitating the dispatch of instructions to the Arduino. The programming logic is elucidated through a flowchart in Fig. 4, which visually represents the sequence control and decision-making processes inherent to the machine's operation.

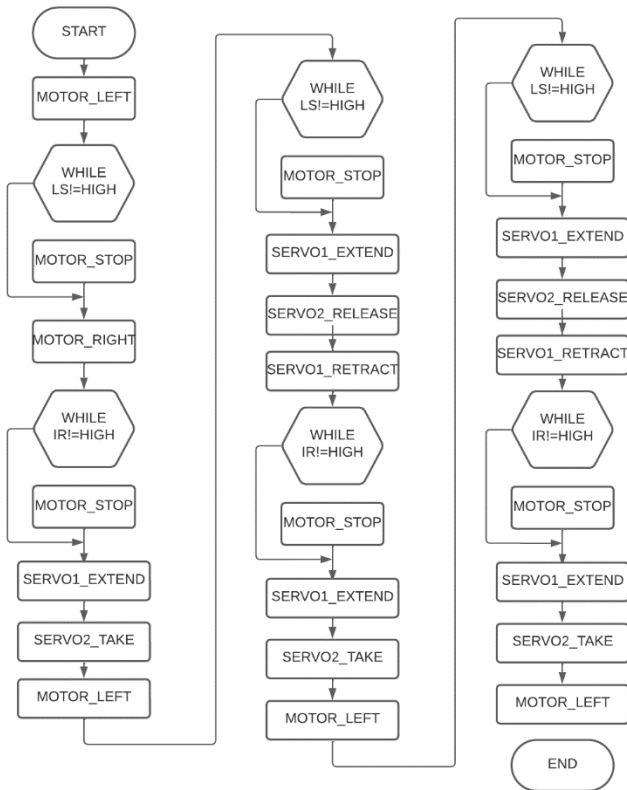

Fig. 4: Programming Flow chart for sorting and palletizing bottles.

The HMI is a critical component that bridges the communication gap between the operator and the machine, enabling intuitive interaction and control. Developed in Thonny using MicroPython, this interface leverages serial communication to transmit textual commands to the Arduino, thereby initiating the sorting and packaging sequences. It also receives data from the Arduino, essential for monitoring the operation, such as bottle count. The HMI is structured into three primary tabs, each serving distinct functions:

**Presentation Tab:** This initial tab displays the machine's name, authors, and affiliated institution, offering users a brief introduction to the machine. This tab serves as a welcoming interface, familiarizing operators with the system they will use.

**Process Tab:** Central to the machine's operation, the process tab contains the control buttons for initiating the bottle sorting, palletizing, and activating the heat gun for shrink sleeve sealing. This functional layout simplifies the operation, streamlining the process for users (see Fig. 5).

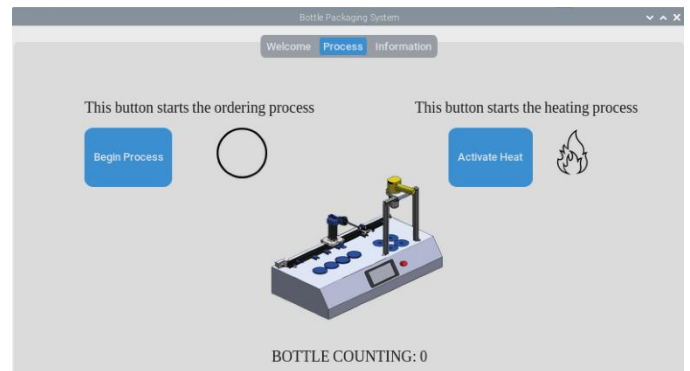

Fig. 5: Process Tab shown in HMI.

**Instructions Tab:** The instructions tab is a broad guide for users, outlining the steps to be followed before and during the machine's operation. This section is vital for ensuring the smooth execution of tasks, prioritizing operator safety, and maintaining the machine's integrity.

The integration of programming and control mechanisms within the machine's design facilitates seamless and efficient operation. By employing a dual-language approach, the system balances operational control and user-friendly interface design, ensuring operators can easily manage the machine's functions while maintaining precise control over its mechanical and electronic components.

### III. MACHINE AND FUNCTIONALITY

Each component's manufacture and the machine's assembly were developed in-house. Fig. 6 shows the front view of the sorting and palletizing machine. In this image, the

two main operating areas of the system are visible. The bottles are located in the left area over the blue circles. Once the bottles are located, the process can be started by pressing the begin button on the screen. The machine takes each bottle from right to left and arranges them on the right area of the machine under the heat gun. Once the four bottles are sorted, the user puts the plastic sleeve over the bottles and starts the heating process by pressing the button active heat on the interface screen. The plastic shrink starts to wrap immediately to palletize the bottles. Fig. 7 shows the final result of the process, a package of four bottles. In order to better understand the sequence of the machine, the following video shows a complete cycle to produce a 4-bottle package: [https://youtu.be/Kgz\\_raCZYDY?si=kPVUeesapPillZ&v](https://youtu.be/Kgz_raCZYDY?si=kPVUeesapPillZ&v).

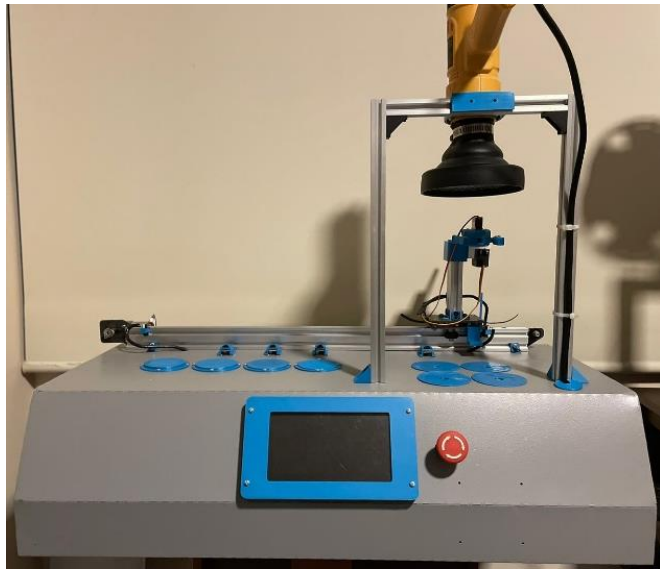

Fig. 6: Final machine ready for validation tests.



Fig. 7: 4-bottle package with plastic film.

#### IV. MACHINE VALIDATION

To check the operation of the sequence, once the whole system was assembled, the bottles were put in the sorting area, and the machine was initialized to test the process and programming. In the same way, the experimentation ensured

that the axial arm could be correctly arranged to move the bottles. This test consisted of operating the robotic arm of the machine ten times. As Table III indicates, the machine achieved an accuracy of 80%. This accuracy was attributed to errors like the cable entangled with the machine base or a wrong position of the limit switch, preventing its operation in all tests. Therefore, remedial measures were implemented, such as introducing a hook to separate the wiring from the robot's base, preventing the servo cable from restricting movement during rack extension. Another correction was adjusting the limit switch position to center the first and second bottles on its base. After these corrections, the test was repeated, and the system achieved an accuracy of 100% in sorting the bottles.

TABLE III  
MACHINE'S SORTING SYSTEM

Number of Tests	It worked	What?	Why?
1	Yes	-	-
2	Yes	-	-
3	No	Z-axis	The cable became entangled with the base of the robot.
4	Yes	-	-
5	Yes	-	-
6	Yes	-	-
7	Yes	-	-
8	No	Bottle 1 has bad positioning	The limit switch had to be positioned differently
9	Yes	-	-
10	Yes	-	-

Once the sorting bottles were tested, the next step was to validate the heating diffuser for the palletizing area. Therefore, A series of tests were developed to achieve functional packaging for bottle distribution. In the first test, the heat supplied solely by the heat gun failed to reach the lateral areas of the bag. Consequently, only the upper and central sections of the bottle group were heated. Addressing this limitation, efforts were made to enhance the heat distribution across the entire bag. It was decided to test 3 mechanisms applied to the heat gun: "air shower", a conical plastic diffuser with a rubber base, and a conical aluminum diffuser with a rubber base.

No positive results were obtained in all the tests performed when the air shower was applied, which consisted of using a steel reducer welded to pipe angles with holes along it to allow the air to flow and reach the lateral parts of the bag.

This is because the heat delivered by the spray gun is not dissipated through the holes in the angles, causing the tube to heat up and the delivered air to exit at a low temperature. By applying the conical plastic diffuser, positive results were obtained in two tests. However, it was impossible to perform the third test because the heat melted the diffuser, causing the plastic through which the heat passes to be discarded. Nonetheless, by keeping the rubber base and replacing it with an aluminum one. There were no problems when applying the sheath since this material allows heat dissipation.

Given these results, it was decided to retain the conical aluminum diffuser with a rubber base. Although, thanks to this implementation, the 4-bottle package already received enough heat to thermoform the plastic bag, it still did not fit perfectly. Therefore, it was decided to carry out tests with 2 different types of bags. 10 tests were carried out with bags of size 28 mm · 35 mm and 10 with bags of size 25 mm · 30 mm. The result of these tests can be seen in Table IV and Table V. As these tables demonstrate, neither of the two options showed efficient heat shrinkage of the plastic bag. In most cases, the package failed, as the bottom of the bottles was not heated enough to shrink the bag. This problem seems to appear since the bags were placed face up, i.e., at the top of the bottles, the bag was sealed, and its opening was at the bottom. This causes the hot air to hit the bag and not pass air to the bottom of the bottles.

TABLE IV  
HEATING TEST WITH BAG DIMENSION OF 28 MM · 35 MM

Number of Tests	It worked	What?	Why?
1	Yes	-	-
2	Yes	-	-
3	No	Loose cover	heat does not reach the bottom
4	No	Loose cover	heat does not reach the bottom
5	No	Loose cover	heat does not reach the bottom
6	Yes	-	-
7	No	Loose cover	heat does not reach the bottom
8	Yes	-	-
9	No	Loose cover	heat does not reach the bottom
10	No	Loose cover	heat does not reach the bottom

TABLE V  
HEATING TEST WITH BAG DIMENSION OF 25 MM · 30 MM

Number of Tests	It worked	What?	Why?
1	Yes	-	-
2	No	Loose cover	heat does not reach the bottom
3	No	Loose cover	heat does not reach the bottom
4	Yes	-	-
5	Yes	-	-
6	No	Loose cover	heat does not reach the bottom
7	Yes	-	-
8	No	Loose cover	heat does not reach the bottom
9	No	Loose cover	heat does not reach the bottom
10	No	Loose cover	heat does not reach the bottom

TABLE VI  
HEATING TEST WITH THE OPENED SLEEVE OF 28 MM · 35 MM

Number of Tests	It worked	What?	Why?
1	Yes	-	-
2	Yes	-	-
3	Yes	-	-
4	Yes	-	-
5	No	Loose cover	heat does not reach the right side
6	Yes	-	-
7	Yes	-	-
8	Yes	-	-
9	Yes	-	-
10	Yes	-	-

To solve the identified problem, a new series of 10 experiments was decided upon. In this case, 25 mm · 30 mm bags were used; However, the bottom of the bags was opened to form an open plastic sleeve; in this way, it was expected that hot air would enter through the 4 bottles and heat the entire package. As can be seen in Table VI, the result of the sleeve shrinkage was positive in 9 of the 10 tests. It was possible to form the 4-bottle packages correctly like those shown in Fig. 7. It is important to highlight that the only package that did not form correctly was due to lack of heat on

the right side. Possibly due to poor placement of the sleeve. Therefore, operator training before operating the machine is recommended when installed in a company.

### V. SYSTEM IMPLEMENTATION COST

To compare the developed system with a commercial approach, Table VII outlines the costs of the system, including the required electronic devices, the mechanical components, and the engineering hours. With all these details, the proposed system costs \$1417.00, considering that the machine was developed in Ecuador. If you compare this value with the cost of the machine of reference [17], the machine's total cost in Ecuador is \$5181.17. The difference between these two prices supposes an estimated savings of \$3764.17, which is a great benefit for an SME. Importantly, the proposed design not only offers cost savings but also ensures optimal capacity for an SME at an affordable cost, providing reassurance about the system's performance.

TABLE VII  
COST RELATED TO MANUFACTURING AND ENSEMBLE OF THE MACHINE

Item	Quantity	Price
Arduino Mega	1	\$22.50
Raspberry Pi4	1	\$65
Aluminium profiles	3 m	\$20/m
Steel structure and machining	1	\$115
toothed belt	1 m	\$7
Dirvers	3	\$20
Pulley	1	\$3.50
Touchscreen	1	\$87
DC Motor	1	\$15
Servomotor	2	\$13.50
Polyethylene sleeve	100	\$11
Presence sensors	4	\$10
Infrared sensors	4	\$12.50
Limit switch	2	\$3
PLA	1 kg	\$22/kg
Heat gun	1	\$30
Hours of engineering	240	\$960
<b>Total</b>	<b>-----</b>	<b>\$1417</b>

### VI. CONCLUSIONS AND RECOMMENDATIONS

In this work, the design and implementation of a sorting and palletizing 4-bottle packs machine was developed. After finishing the research, the following conclusion can be highlighted.

- Thanks to the application of the mechatronic methodology, it was possible to synchronize the mechanical components with the electronic devices and the programming sequence to create a functional system capable of sorting and palletizing 4-bottle packages.
- After the validation tests, the system corrections improved the model's accuracy for sorting the bottles to 100%. In the same way, the test developed for the heating gun allows the selection of a heating system with a conical aluminum diffuser. In conjunction with the open plastic sleeve of dimension 25 mm · 30 mm, this diffuser created perfect 4-bottle packages in the pelletizing area.
- For future endeavors, the authors consider incorporating diverse electronic components, such as stepper motors or ultrasonic sensors, which might enhance the axial arm's functionality. Additionally, it is considering adding an extra degree of freedom in the axial robot to expand its versatility to accommodate various types of bottles.

### REFERENCES

[1] C. Torres, "Diseño De Un Sistema Automático Para El Proceso De Embalaje De Pallets," *Repos. Pucp*, p. 369, 2021.

[2] Santini Argentina SLR, "Formado de Pack LT-500," <https://www.youtube.com/c/Santiniargentina/videos>, 2015.

[3] Toapanta, J., "Diseño y construcción de un prototipo para una máquina semiautomática envolvente de palets portátil con plataforma giratoria y sistema de sujeción de film," *BS thesis*. 2014.

[4] Domínguez, L., and Villarroel E. J., "Máquina Automática para Embalar Pallets con Monitoreo EXSCADA," p. 194, 2007, [Online]. Available: <https://repositorioacademico.upc.edu.pe/handle/10757/273544>

[5] Loyo, A., and Rodríguez, M., "Diagnóstico de computadoras automotrices in circuit mediante la parametrización de variables de importancia," *BS tesis*, 2020.

[6] Val, C. G. "Robot Cartesiano de tres ejes controlado por computadora" [en línea]. Trabajo final. Pontificia Universidad Católica Argentina. Facultad de Ciencias Fisicomatemáticas e Ingeniería. 2009. Disponible en: <https://repositorio.uca.edu.ar/handle/123456789/11220>



- [7] Aristizába, J., "Implementación de algoritmos de control de velocidad y torque de motores de corriente continua aplicados a un modelo de AGV multipropósito de potencia media utilizando Raspberry Pi," *Psikol. Perkemb.*, no. October 2013, pp. 1–224, 2019.
- [8] Haines, T. and Joyce, F., "Raspberry Pi Human Machine Interface and Control System for an Electromagnet Water Filter," *Proc. Annu. Mont. Tech Electr. Gen. Eng. Symp.*, vol. 19, p. 47, 2017, [Online]. Available: <http://digitalcommons.mtech.edu/engr-symposium%0Ahttp://digitalcommons.mtech.edu/engr-symposium>
- [9] Ke, Ding. "Case packing system for bottle preform based on coordinate robot manipulator." *Food and Machinery*, 201.
- [10] Abhinav Baroorkar, et al., "design of an automated bottle packaging system," *Int. J. of Adv. Res.* 9 (May), 2021, pg1311-1315, <http://dx.doi.org/10.21474/IJAR01/12972>
- [11] Dzitac, P. and Mazid, A. M., "An Efficient Control Configuration Development for a High-speed Robotic Palletizing System," 2008 *IEEE Conference on Robotics, Automation and Mechatronics*, Chengdu, China, 2008, pp. 140-145, doi: 10.1109/RAMECH.2008.4681379.
- [12] Baldassarri, A., et al., "Development of a mobile robotized system for palletizing applications," *25th IEEE Int. Conference on Emerging Technologies and Factory Automation (ETFA 2020)*, Vienna, Austria, 2020, pp. 395-401. doi: 10.1109/ETFA46521.2020.9212124
- [13] Kai Lia , Guofu Luo, and Yunlong Li., "Modeling and Simulation of Water Bottle Packaging Production Line," *4th International Conference on Automatic Control and Mechatronic Engineering (ACME)*, 2019.
- [14] Denise, P., "Heat shrink sleeves for MB/BacTm Bottles" (1996). *Thesis. Rochester Institute of Technology*. Accessed from <https://repository.rit.edu/theses/278>
- [15] Gausemeier, J., Moehring, S., "VDI 2206- A New Guideline for the Design of Mechatronic Systems," *IFAC Proceedings Volumes*, Volume 35, Issue 2, 2002, Pages 785-790, [https://doi.org/10.1016/S1474-6670\(17\)34035-1](https://doi.org/10.1016/S1474-6670(17)34035-1).
- [16] Gerschütz, B. et al., "Digital Engineering Methods in Practical Use during Mechatronic Design Processes," *Designs* 2023, 7, 93. <https://doi.org/10.3390/designs7040093>
- [17] Heat shrink wrap machine ZONESUN at AliExpress. Available at: [https://es.aliexpress.com/item/1005006664085588.html?spm=a2g0o.productlist.main.1.5eeb6809yGkiiB&algo\\_pvid=931682fa-4d69-40ef-8431-46c52c73e0aa&algo\\_exp\\_id=931682fa-4d69-40ef-8431-46c52c73e0aa-0&pdp\\_npi=4%40dis%21USD%21493.75%21404.87%21%21%21493.75%21404.87%21%402103273e17150481371737748e2ef%211200037959741426%21sea%21EC%210%21AB&curPageLogUid=3ZW6XJvIkVy5&utparam-url=scene%3Asearch%7Cquery\\_from%3A](https://es.aliexpress.com/item/1005006664085588.html?spm=a2g0o.productlist.main.1.5eeb6809yGkiiB&algo_pvid=931682fa-4d69-40ef-8431-46c52c73e0aa&algo_exp_id=931682fa-4d69-40ef-8431-46c52c73e0aa-0&pdp_npi=4%40dis%21USD%21493.75%21404.87%21%21%21493.75%21404.87%21%402103273e17150481371737748e2ef%211200037959741426%21sea%21EC%210%21AB&curPageLogUid=3ZW6XJvIkVy5&utparam-url=scene%3Asearch%7Cquery_from%3A)