



Regenerative Braking System for an Electric Motorcycle Model Sakura M500

Edgar Andre Manzano, Master  and Wily Marco Narciso, Engineer 

¹Universidad Privada del Norte, Peru, edgar.manzano@upn.pe

²Universidad Nacional de Trujillo, Peru, marco@gmail.com

Abstract– Electric mobility development is rapid spreading in the most advanced countries of the world because of the high efficiency showed by the current electric vehicles (EVs). On this line, Latin America has started the inclusion of these technologies in some countries. Nevertheless, despite the technological development of EVs, such as electric motorcycles, there are still pending investigations regarding the increase in their autonomy. The present research proposes a regenerative braking system for a specific electric motorcycle: Model Sakura M500, with the purposes of increase the autonomy of the mentioned EV. The VDI 2206 methodology is applied to the development of the regenerative braking system, including conceptual design, detailed design and experimental tests; concluding with positive outcomes of autonomy.

Keywords– Electric Motorcycle, Regenerative Braking System, Model Sakura M500, Electric Vehicles, VDI 2206 methodology.

I. INTRODUCTION

Although, the urban mobilization has not been always the most efficient economical and viable, a big step was the introduction of hybrid electric vehicles which led to new technological advances in lithium batteries and greater inclusion of EVs in the market [1]. In addition, drastic depletion in the quantity of carbon fuels, boom manufacture in automobiles, maximizing the regeneration of energy and usage of renewable energy is turning into a main concern [2]. Therefore, EVs are increasingly spreading, their advantages are that they do not pollute the environment, higher efficiency, reverse and stop-mode operation, higher acceleration, noise, lower cost per kilometer road [3]. On this line, [4] claims “each and every drop of fuel saves our economy and meet the needs”.

EVs present a really promising scenario, data shows sales doubled in 2021 from the previous year, the origin of this increase is meanly thanks to people from China, the Europe Union (EU) and the United States (USA); and nowadays, the market behavior is very similar [5]. According to this trend, by 2030 there would be 355 million passenger electric vehicles on the road and by 2050 some 90-95% of all vehicles would be electric [6].

Latin American countries have been already implementing diverse public incentives to impulse the use of EVs. Governments are reducing taxes and promoting rebates to cut down the cost of EVs. Brazil, Colombia, Costa Rica and Mexico are offering full exemption from the import tax. In addition, there are nonfinancial incentives and other types of efforts of promotion [7]. For example, in Santiago (Chile), 411 e-buses were integrated to the fleet, which represented approximately the 6%, highlighting maintenance costs 66% cheaper than diesel buses [8].

The aforementioned development has attracted the interest of manufactures in the two-wheeler market, all of this allowed growth in the area of electric motorcycles in the last decade [1]. Thus, regenerative-friction braking systems in motorcycles have attracted much attention due to the increase in energy demand. Regenerative braking system is an energy recovery system that recover significant amount of kinetic energy of the vehicle. [4]. Nonetheless, without proper energy management, the battery lifetime may be negatively affected by the recurrent energy produced from braking [1, 9].

For that reason, energy regeneration systems have been developed in which the electric motor operates in a generator mode and the resulting electricity is used to power the on-board systems and to charge the battery. It is possible to use the rear brake only and therefore all the energy consumed during braking to regenerate until a certain braking delay. When the braking delay increases, the percentage of recovered energy decreases [3].

Many researches have been developed related to this field. For instance, for e-bikes the design and control methodology of an electric bike which focuses on the efficient usage of battery using regenerative braking system is presented in [4], and in [10] is proposed a design to increase the efficiency of the motor of an E-Bike by simply managing the energy better and utilizing the regenerative braking process with the help of a BLDC Motor using PWM Technique [10].

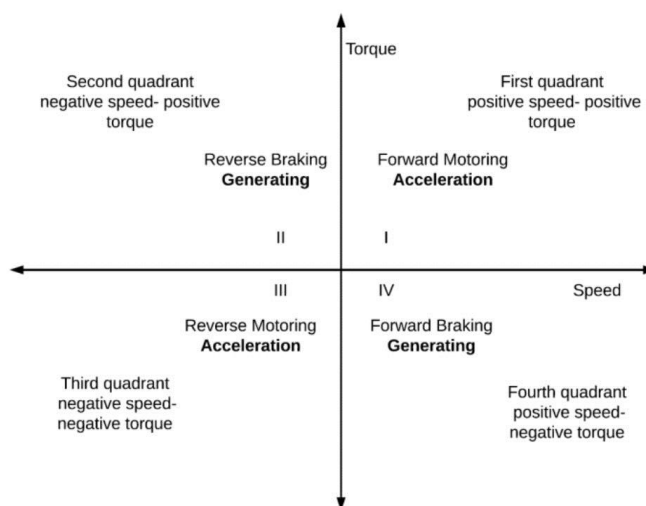

Fig. 1 Four quadrant operation for a BLDC motor.

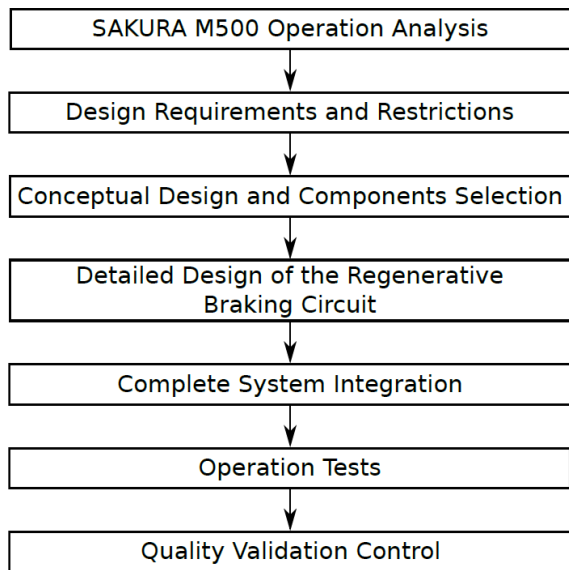

Fig. 2 Flowchart for the Development of Regenerative the Braking System.

Talking about regenerative braking strategies in electric motorcycles, an optimal regenerative braking control scheme for a permanent magnet brushless DC motor of an electric motorcycle is proposed by [11], a novel strategy to manage the decelerations of an electric motorcycles as requested by the driver is presented in [12], and an intelligent regenerative-friction braking system in electric motorcycles using Fuzzy Inference System (FIS) optimized via Whale Optimization Algorithm (WOA) has been developed by [9]. Furthermore, a design of a functional electric motorcycle prototype is carried out by [1] and the design consideration of chassis, power train and choose of battery pack with “Battery Management System”, which aim is to design an efficient electric motorcycle that helps to reduce pollution from environment is developed by [13]. Nevertheless, despite several advances in regenerative braking strategies for EV applications, all of these remain very limited [12].

The objective of this research is the development of a regenerative braking system for a specific electric motorcycle SAKURA M500, evaluating the increase of autonomy of the machine.

II. REGENERATIVE BRAKE

For a regenerative brake, a full-wave or even half-wave converter must be operated, where it is only a matter of converter control, essentially the direction of the stator currents must be changed under the same poles to obtain a torque in the opposite direction. This leads to obtaining motor braking while maintaining the direction of rotation, in addition to inverting the direction of the currents in the phases, it is enough to manipulate the sequences of the converter in the opposite direction. Within the mode of operation for regenerative braking in brushless DC motors (BLDC), the torque-angular velocity plane presented in

Fig. 1 must be taken into account, where it shows when it is working as a regenerative motor or brake [14, 15].

It should also be considered that the regeneration is always below the maximum angular speed, that is, when the vehicle is moving with a speed lower than the maximum allowed, either due to inertia on slopes, the motor will be generating electricity, but it will not always be at the same time. voltage of the batteries, therefore the step of the DC-DC converter must be taken into account in raising the voltage between the motor generator and the power source [15].

III. DEVELOPMENT OF THE REGENERATIVE BRAKING SYSTEM

The procedure to develop the regenerative braking system could be summarized by the Fig. 2. Subsequently, each step is detailed in the following subsections.

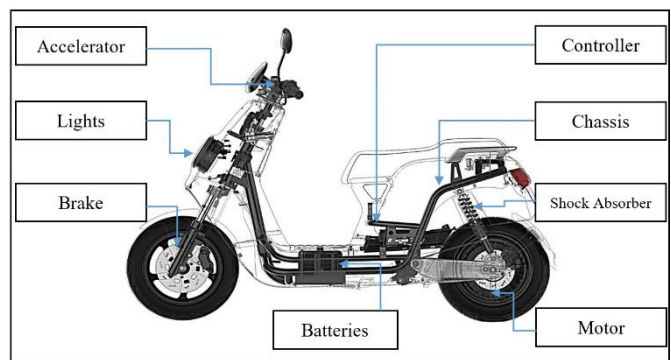

Fig. 3 Main elements of the Motorcycle Sakura M500.

A. Sakura M500 Analysis

Firstly, an identification of the motorcycle structure was made, considering the elements detailed in Fig. 3. Here, accelerator, brake, batteries, controller and the motor are the more remarkable for the design of the regenerative braking system.



Fig. 4 Motorcycle's route without regenerative braking system.

The regular motorcycle's operation is centralized by the controller, which utilize the energy stored in batteries to

activate the electric motor. An important detail is that the motor does not require a transmission stage, due to stator is static and the rotor is directly connected to the wheel.

TABLE I
LIST OF REQUIREMENTS

Requirement	D/W	Description
Primary Function	D	To convert kinetic energy of the motor's motorcycle to electric energy that will be stored in the battery (in order to increase the autonomy's motorcycle)
Energy	D	To convert the three-phase signal of the motor to DC current to feed batteries. Restriction: Input voltage is AC three phase of $V_{pp}=120V$. Output voltage should be higher than DC 72V to charge the batteries.
Operation Logic	D	To identify the brake handlebar, motorcycle inclination and minimum voltage required to feed batteries (in order to start the converting process). Restriction: The system should activate the regenerative brake when downhill slope is equal or greater than 4 degrees.
Signals	W	To show information of voltage and inclination angle.
Assembly	W	Modular system.
Cost	W	Do not exceed \$54.
Maintenance	W	Easy cleaning and replacement.

Sakura M500 datasheet details every important motorcycle characteristic such as 1500W motor, 74V 20AH battery and 50 km of autonomy. Nonetheless, the performance results obtained after a few tests of autonomy, using Adidas Running app as support in the route shown by Fig. 4, are summarized in the following list:

- Distance: 34.86 km
- Time duration: 01: 20: 24
- Media vel.: 26.1 km/h
- Max. vel.: 47.8 km/h

Evaluating the data, apparently, making a comparison with the manufacturer datasheet, there is an autonomy reduction due to the component's deterioration of 2 years of use, which would include batteries.

B. Design Requirements and Restrictions

The process of design is developed according the VDI 2206 guidelines [16]. Therefore, it was determined the list of requirements which will define the design parameters and objectives. Table 1 summarize the requirements list, where D means Demands and W Wishes.

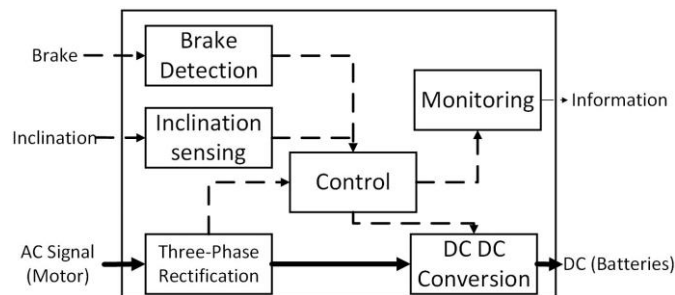

Fig. 5 Functional Structure of the Braking System.

C. Conceptual Design and Component Selection

In this stage, the conceptual design and components selection are also performed according the VDI 2206 methodology.

1) *Functional Structure:* Firstly, functional structure of the regenerative braking system is detailed in Fig. 5, this diagram is determined in order to meet the requirements list, which was previously defined. One detail important to explain is the energy conversion, as it is necessary a conversion from three-phase AC signal (from the regenerative brake, thus, variable) to DC Voltage for the batteries, it was practically mandatory the utilization of a three-phase rectifier + DC DC Boost Converter.

TABLE II
MORPHOLOGICAL MATRIX

Functions	Option 1	Option 2	Option 3
Brake detection	Brake sensor		
Inclination sensing	MPU6050	QMC5883L	HMC5883L
Three-phase rectification	Diodes Circuit	Bridge Rectifier	
Controller	Arduino NANO	Arduino MEGA	Node MCU
DC DC Conversion	Boost 600W	Boost 1200W	Boost Design
Monitoring	OLED screen	LCD screen	

2) *Morphological Matrix:* Starting from the functional structure, different alternatives of devices are summarized in the morphological matrix shown in Table II to fulfill the functions considered in the functional structure. Then, they are chosen 3 main alternative of solution concepts as the combination of the alternatives of the matrix, especially considering the compatibility between devices.

3) *Solution Concept:* After analyzing the alternatives of solution found in the morphological matrix, and considering the fulfillment of the functions described by the list of requirements, and also the restrictions; a weighting matrix is elaborated including all the factors aforementioned, in order to compare the candidates of solution concept. Finally, it is obtained the solution concept that is described by the Fig. 6.

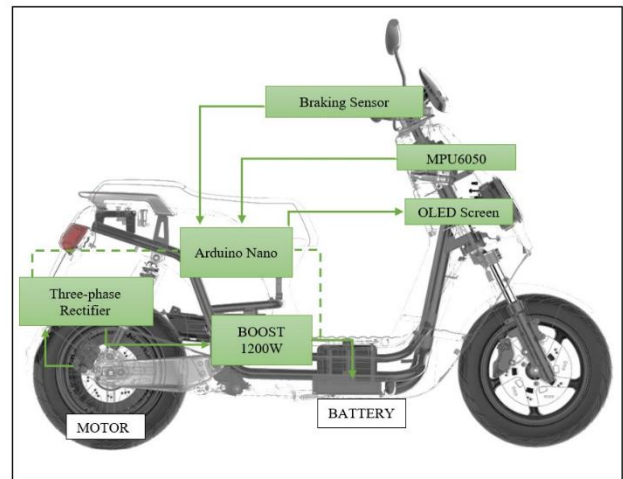

Fig. 6 Electric Motorcycle Solution Concept

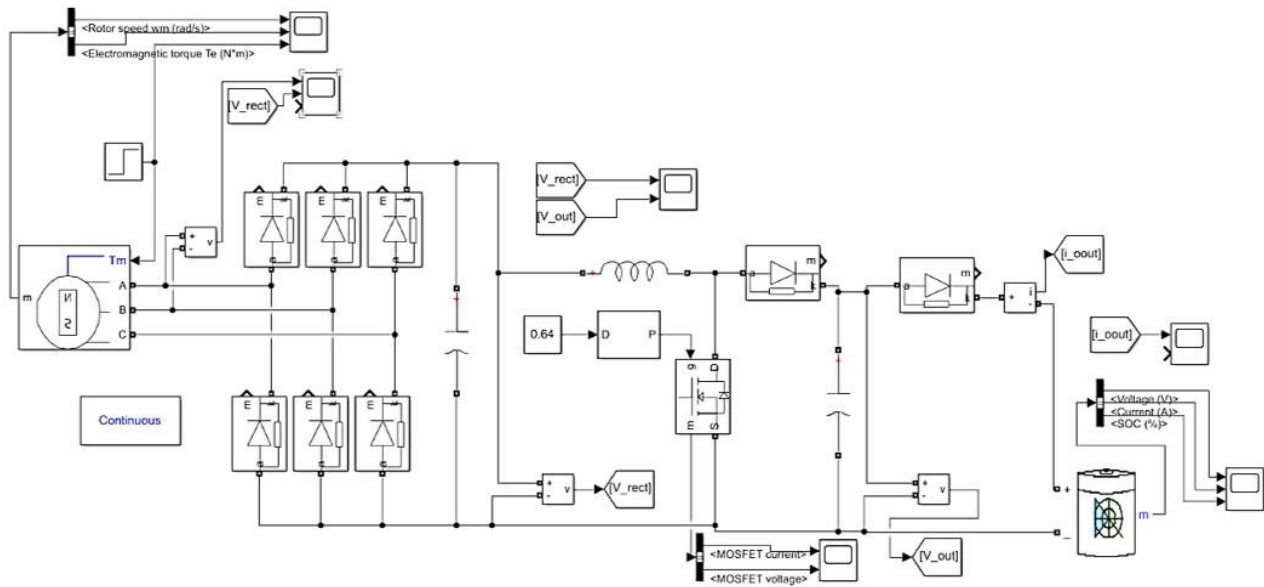

Fig. 7 Simulation schematic of the Regenerative Braking System

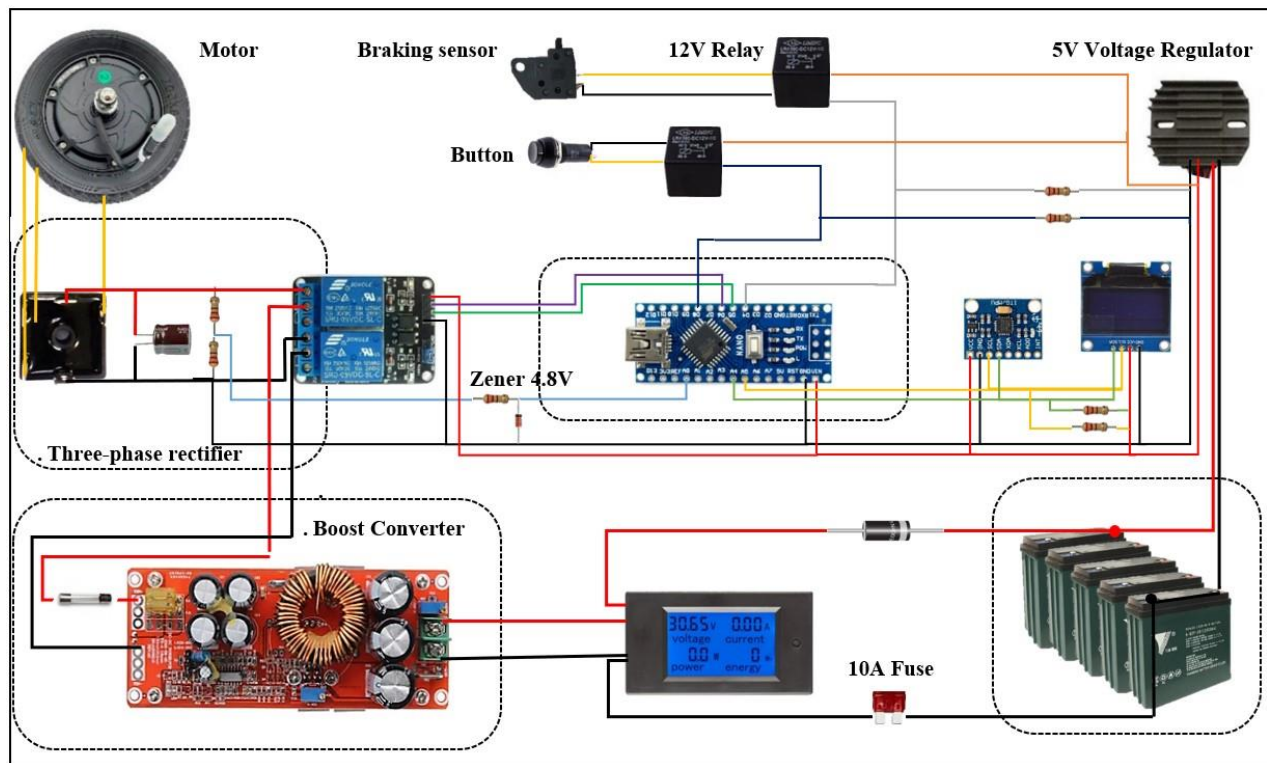

Fig. 8 Regenerative Braking System Architecture

D. Detailed Design of the Regenerative Braking Circuit

1) *Simulation*: A simulation was conducted especially considering two main stages: rectifier and DC DC converter, consequently, it was considered the effect of the motor (source of energy in the braking operation) and the battery (storages). Fig. 7 shows the Simulink schematic that represents the

regenerative braking circuit, it is important to claim Batteries considered in the design are of 72V.

2) *Architecture of the System*: Considering the solution concept previously defined. It is evaluated the adaptation and start-up of all the selected components, concluding in the architecture presented in Fig. 8.

3) *Algorithm in the Microcontroller:* The algorithm implemented in the controller is represented by the flowchart of Fig. 9, where it is remarked the importance of the activation and deactivation variables

- Activation variables:
 - Inclination angle (≥ 4 degrees).
 - Voltage divider output (acceptable range).
 - Braking signal of the motorcycle.
 - Switch activated (for protection).
- Deactivation variables:
 - Inclination angle (< 4 degrees).
 - Voltage divider output (out of the range).
 - Switch deactivated (for protection)

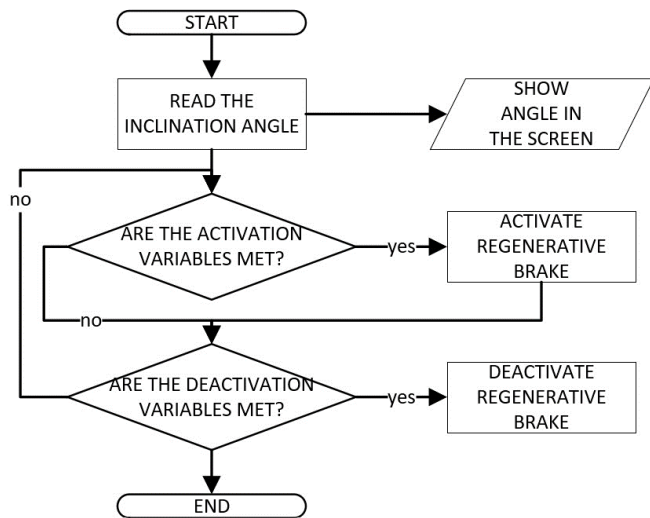

Fig. 9 Flowchart of the Controller's Algorithm

E. Complete System Integration

In this part, all stages of the circuit are connected to each other, obtaining the board detailed in Fig. 10. The circuit is considered in a modular way in order to meet with the list of the requirements previously defined.

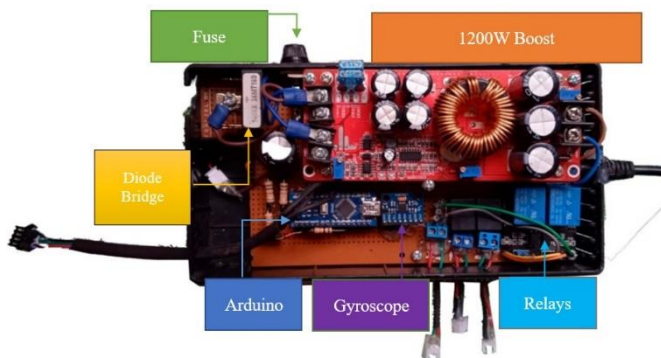

Fig. 10 Circuit board including modular components

Finally, the complete circuit is integrated to the electric motorcycle, considering the connections detailed in Fig.11,

adapting some connectors of sensors and actuator to assure a correct functioning of the regenerative braking system.

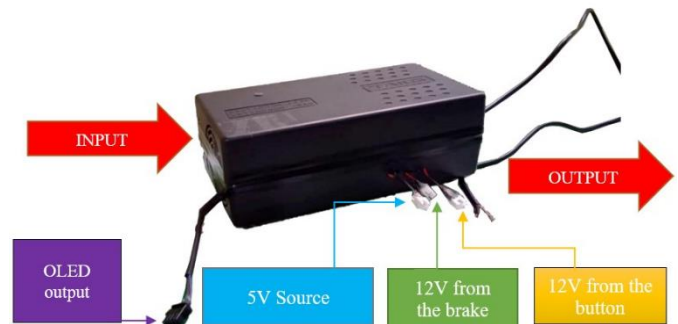

Fig. 11 Regenerative braking circuit container and connections

IV. EXPERIMENTAL TESTS

The aim of the present research is the increase of autonomy of the SAKURA M500 electric motorcycle. Thus, it is tested through different operation tests in Trujillo city (Peru). In order to get data of the system operation, Adidas Running app was used, which is based in the Global Positioning System (GPS) principle. In the following lines, they are detailed the three main tests discussed.

The first test data is detailed in Fig. 12, where it is distinguished a total distance of 36.92 km in 1 hour and 23 minutes, thus, 2 more kilometers of autonomy.

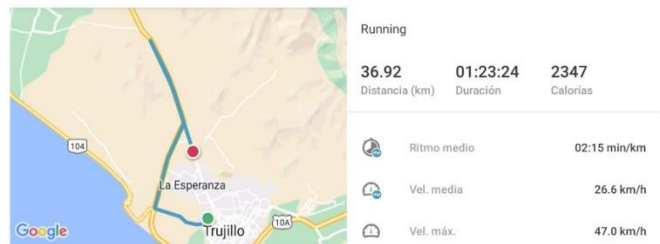

Fig. 12 First Test of Regenerative Braking System Operation

Fig. 13 shows data from the second experiment, obtaining a total distance traveled of 36.6 km in 1 hour and 24 minutes. In addition, it is important to remark that the regenerative braking system was activated 6 times.

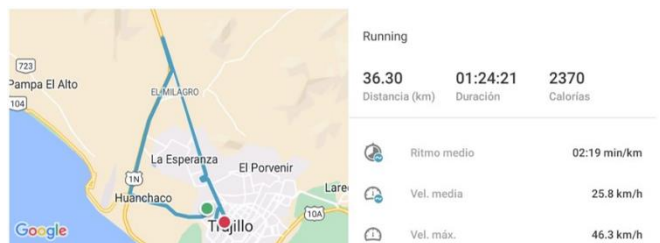

Fig. 13 Second Test of Regenerative Braking System Operation

The last important test to share is shown by Fig. 14. The outcomes are similar than the other tests, 36.19 km in 1 hour and 25 minutes, with 6 activations of the braking system.

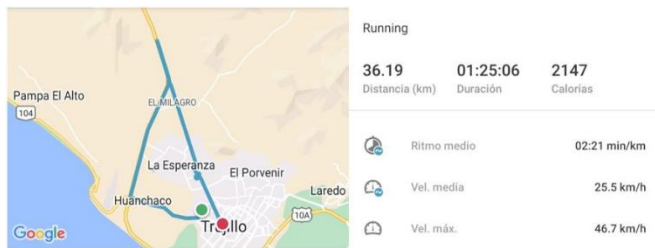

Fig. 14 Third Test of Regenerative Braking System Operation

It is important to point out, that the three experiments were performed in similar routes, with certain differences because of the search of inclined paths.

V. DISCUSSION

The data collected in the experiments aforementioned are summarized in Table III.

TABLE III
SUMMARY OF THE AUTONOMY TESTS

Criteria	Test 1	Test 2	Test 3
Initial distance	34.86 km	34.86 km	34.86 km
New distance (including regenerative brake)	36.92 km	36.30 km	36.19 km
Increase of Autonomy	2.06 km	1.44 km	1.33 km
Gain (%)	6 %	4 %	4 %

The increase of autonomy achieved by the regenerative braking system for the Sakura M500 electric motorcycle belongs a range of 1 to 2 km, with an average percentage gain of 4.6%, which is similar to the results estimated by others works focused in electric bikes.

For instance, the research performed in [4], where it is expected an outcome of 5 – 10% gain in charge for the regenerative braking system (not autonomy); another case is [17], with an increase of autonomy of 126 m (lower than our proposal), however, it means an average gain of 7% because we are talking about an electric bike.

REFERENCES

[1] S. Reckziegel, A. Guerrero, and M. Arzamendia, "Analysis and design of a functional electric motorcycle prototype," in 2021 IEEE CHILEAN Conference on Electrical, Electronics Engineering, Information and Communication Technologies (CHILECON). IEEE, 2021, pp. 1–6.

[2] P. Shenil et al., "Novel regenerative braking controllers for electric vehicle driven by bldc motor," in 2021 Fourth International Conference on Electrical, Computer and Communication Technologies (ICECCT). IEEE, 2021, pp. 1–6.

[3] G. Yanachkov and S. Hesapchieva, "Integral brake system for electric motorcycle using maximum energy regeneration."

[4] B. Chandru, H. Kumar, K. S. Narendiran, and P. Manju, "Design of electric vehicle with the help of regenerative braking system," in *Advances in Automation, Signal Processing, Instrumentation, and Control: Select Proceedings of i-CASIC 2020*. Springer, 2021, pp. 995–1003.

[5] IEA Publications. International Energy Agency. Accessed May. 5, 2023. [Online]. Available: <https://iea.blob.core.windows.net/assets/ad8fb04c-4f75-42fc-973a-6e54c8a4449a/GlobalElectricVehicleOutlook2022.pdf>

[6] BloombergNEF. Bloomberg. Accessed May. 5, 2023. [Online]. Available: <https://about.bnef.com/new-energy-outlook/>

[7] J. Quirós-Tortós, L. Victor-Gallardo, and L. Ochoa, "Electric vehicles in latin america: Slowly but surely toward a clean transport," *IEEE Electrification Magazine*, vol. 7, no. 2, pp. 22–32, 2019.

[8] World Bank Publications. The World Bank. Accessed May. 5, 2023. [Online]. Available: <https://documents1.worldbank.org/curated/en/656661600060762104>

[9] A. Samii, F. Lotfi, and H. D. Taghirad, "Optimization of battery life and state of the charge in an electric motorcycle braking system," in 2021 9th RSI International Conference on Robotics and Mechatronics (ICRoM). IEEE, 2021, pp. 203–209.

[10] S. Nayak, R. Bhatt, and R. Sarmal, "Regenerative braking of a bldc motor using pwm technique," Institute of Science Technology, SRM Nagar, Kattankulathur- 603-203. Kancheepuram Dist., Tech. Rep., 2022.

[11] W. Cui, H. Zhang, Y.-l. Ma, and Y.-j. Zhang, "Regenerative braking control method and optimal scheme for electric motorcycle," in 2011 International Conference on Power Engineering, Energy and Electrical Drives. IEEE, 2011, pp. 1–6.

[12] J. Nadeau, F.-A. Lebel, P. Messier, J. P. Trovao, and A. Desrochers, "Novel ergonomic regenerative braking system for an electric motorcycle," in 2018 IEEE Vehicle Power and Propulsion Conference (VPPC). IEEE, 2018, pp. 1–6.

[13] S. S. Thakur, E. A. Roy, S. Dhakad et al., "Design of electric motorcycle," in 2020 IEEE International Students' Conference on Electrical, Electronics and Computer Science (SCEECS). IEEE, 2020, pp. 1–4.

[14] S. Tiwari and S. Rajendran, "Four quadrant operation and control of three phase bldc motor for electric vehicles," in 2019 IEEE PES GTD grand international conference and exposition Asia (GTD Asia). IEEE, 2019, pp. 577–582.

[15] D. O. Spencer Vargas, "Diseño e implementación de freno regenerativo para motor de corriente continua sin escobillas con amanes permanentes para moto eléctrica," Universidad de Chile, Tech. Rep., 2019.

[16] J. E. Vidal, "Sysml como herramienta para garantizar la trazabilidad de requerimientos en el diseño mecatrónico," Pontificia Universidad Católica del Perú, Facultad de Ciencias e Ingeniería, Tech. Rep., 2018.

[17] J. D. Toral Valdivieso, "Desarrollo del freno regenerativo en un motor sin escobillas para una bicicleta," Universidad Politécnica Salesiana, B.S. thesis, 2019.

Digital Object Identifier: (only for full papers, inserted by LACCEI).

ISSN, ISBN: (to be inserted by LACCEI).

DO NOT REMOVE