

# Solar and Wind Energy Potential Assessment in a University Building under a Tropical Climate

Orlando Aguilar Pinzón, Engineer<sup>1</sup>, Orlando Aguilar Gallardo, Ph.D.<sup>1</sup>, Miguel Chen Austin, Ph.D.<sup>1,2,3,\*</sup>

<sup>1</sup> Facultad de Ingeniería Mecánica, Universidad Tecnológica de Panamá, Ciudad de Panamá, [orlando.aguilar1, orlando.aguilar, miguel.chen]@utp.ac.pa

<sup>2</sup> Centro de Estudios Multidisciplinarios en Ciencias, Ingeniería y Tecnología (CEMCIT-AIP), Ciudad de Panamá, Panamá

<sup>3</sup> Sistema Nacional de Investigación (SNI), Clayton Ciudad de Panamá, Panamá

\*Corresponding author: [miguel.chen@utp.ac.pa](mailto:miguel.chen@utp.ac.pa)

**Abstract**— This paper presents the design and performance analysis of a hybrid wind and solar energy generation system integrated with a battery bank for a building. The objective of this study is to evaluate the extent to which the energy demand of the building can be met by the hybrid system and to investigate the effects of various parameters on system performance. The hybrid system comprises nine wind turbines, a solar photovoltaic (PV) array, and a battery bank, all integrated with the building's electrical grid. A simulation model is developed using Designbuilder/EnergyPlus to estimate the energy demand of the building. This model considers the building's energy consumption, weather data, and the wind turbine and PV array characteristics. The simulation results show that the hybrid system can effectively cover a significant portion of the building's energy demand. The battery bank plays a crucial role in ensuring a continuous electricity supply. The effects of various parameters, such as wind speed, solar irradiation, and battery capacity, on system performance, are also analyzed. The results show that the designed generation system could fulfill up to 34% of the buildings energy demand for the month of March. The findings of this study can serve as a basis for the optimization of hybrid renewable energy systems for building applications, thereby contributing to the development of sustainable energy solutions.

**Keywords**—buildings, renewable energy, solar, tropical climate, wind.

## I. INTRODUCTION

There is an unprecedented energy crisis at a global level [1]. This is due to the rapidly increasing demand for energy from a rapidly growing world population, together with the need to replace traditional energy sources with clean and sustainable ones to mitigate the impacts of climate change that we have caused. Non-renewable energy sources dependent on fossil fuels have proven to be insufficient in meeting these challenges, which has led to the emergence of Distributed Renewable Energy Sources (DRES)[2]. DRES refers to decentralized generation and distribution of renewable energy, typically at the community or household level, providing a more sustainable and reliable source of clean energy [3].

DRES may be able to change the energy landscape by further reducing the dependence on non-renewable sources [3]. They also hold certain advantages over centralized energy

systems, like the challenges created by grid constraints, high cost of energy, and limited access to energy in certain areas, providing independence to communities, particularly in rural or remote areas, where grid connections are either limited, unreliable or simply non-existent [4]. This last point is an important one, as DRES can help to address energy poverty, by providing access to energy to those who lack it.

In Panama, renewable energy sources such as hydropower, wind, and solar are becoming increasingly popular alternatives to traditional fossil fuels [5]. There is considerable investment by the country to support the growth of these industries and constantly increase the proportion of energy derived from renewable sources. However, fossil fuels, particularly oil and natural gas, still play a significant role in the energy mix of the country [6]. This is in part due to the dry season lowering the amount of available water in dams and rivers to produce energy, especially since hydroelectric energy has the highest percentage of the energy source mix by a large margin.

The aim of this paper is to provide a comprehensive overview of DRES and its potential to shape the energy future. The paper will showcase a theoretical distributed energy generation system created for Building #1 of the Victor Levi Sasso campus of the Universidad Tecnológica de Panamá-UTP- (Technological University of Panama). This system is based on solar and wind energy, with a battery bank available for storing a certain amount of energy for some level of autonomy.

The authors believe that DRES are a crucial component of the clean energy future and have a significant role in meeting the energy demands of the world while reducing dependence on non-renewable energy sources. The decentralization of energy generation and distribution can provide a more sustainable and equitable energy system. The authors also hope that this paper will contribute to the ongoing discourse on DRES and encourage further research and investment in this promising field.

## II. METHODOLOGY

The purpose of this study is to evaluate the feasibility of distributed energy generation as a means of increasing energy security and reducing carbon emissions. The study focuses on the deployment of small-scale renewable energy sources, such

**Digital Object Identifier:** (only for full papers, inserted by LACCEI).  
**ISSN, ISBN:** (to be inserted by LACCEI).  
**DO NOT REMOVE**

as solar panels and wind turbines, in residential and commercial areas. March was chosen as the month of analysis for this study, since it has the highest thermal loads of the year due to it being the height of the summer heat, coupled with regular classes in the whole building. As previously mentioned, the case of study in this instance is Building #1 of the Victor Levi Sasso campus of the Technological University of Panama with coordinates 9°01'25" North, 79°31'54" West, shown in Fig. 1.



Fig. 1. Building #1 in the Victor Levi Sasso Campus of UTP: (a) axonometric view (b) plant view. Source: The authors

The energy sources chosen for this system were wind and solar, together with a battery bank to store excess energy. The methodology for the design is different from how it is usually taught: instead of designing the generation system taking into consideration the load of the building, this system was designed considering the available space in the roof of this building for the solar panels and wind turbines.

Fig. 1(b) shows a top-down view of the building chosen as the case of study. The complete available roof space for the installation of the whole system is of 3,872.12m<sup>2</sup>. The space allocated for the wind turbines is the left edge of the roof as seen in the photo, since this space is clear of trees and not in full view when arriving at the building through the front entrance. The rest of the available roof space would be covered in solar panels.

#### A. Wind energy system sizing

The process for wind sizing was comprised of the following steps:

1. Selection of the equipment
2. Selection of the sizing method
3. Calculation of available surface area for wind turbines
4. Calculation of generation capacity

The steps were performed as follows:

1) *Selection of the equipment:* The authors wish to state that since this design is purely theoretical, the equipment chosen will not take into consideration the monetary factor, but instead only choosing from the best available equipment. Several models were initially considered, however unlike solar panels, the best available wind turbine is subjective, depending on several factors like the local geography, climate, elevation, and the voltage of the battery bank. Ultimately the turbines chosen for this were the Renova Wind EOS 1kW [7]. The reason this turbine model was used is that Renova Wind is a Panamanian company with experience and local knowledge. They were contacted to help in the task of choosing a turbine model taking into consideration the previously mentioned parameters. The Renova Wind EOS 1kW is a relatively small, vertical shaft turbine, as shown in Fig. 2. Because of this vertical design, the wind direction is a parameter that does not need to be considered, and the ease of installation means that they can be mounted on vertical shafts installed on the sloped roof without any issues.

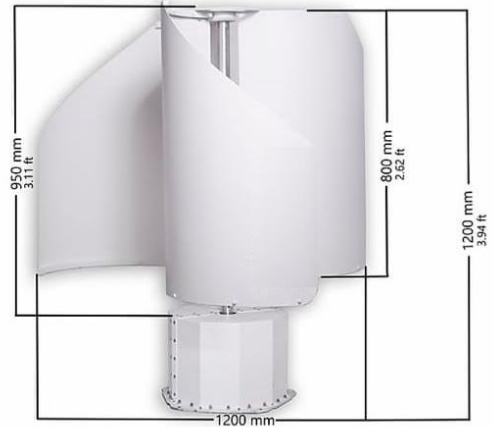

Fig. 2. Renova Wind EOS 1kW wind turbine. Source: <https://renovawind.com/en/solutions/business-solutions>

2) *Selection of the sizing method:* The calculations for the generation capacity were then performed using the Weibull Method for wind frequency [8], following (1)-(3):

$$f(v) = \left(\frac{k}{c}\right) \left(\frac{v}{c}\right)^{k-1} e^{-\left(\frac{v}{c}\right)^k} \quad (1)$$

$$k = \left(\frac{\sigma}{\bar{v}}\right)^{-1.086} \quad (2)$$

$$c = \frac{\bar{v}}{\Gamma\left(1+\frac{1}{k}\right)} \quad (3)$$

Where  $f(v)$  is the Weibull wind frequency,  $k$  and  $c$  are the shape and scale parameters respectively,  $v_i$  is the wind speed at each step of the turbines power curve,  $\sigma$  is the standard deviation of the wind speed measurements within the selected period,  $\bar{v}$  is the average wind speed within the selected period, and  $\Gamma$  is the gamma function used by the software Microsoft Excel.

For simplicity in performing these calculations, the equations were programmed into an Excel spreadsheet, only needing an input of certain information such as the power curve for the turbine in question, and the parameters relevant to the local geography of the case of study.

There are two more expressions (4) and (5) necessary for the sizing:

$$v_h = v_{h_r} \left(\frac{h}{h_r}\right) \quad (4)$$

$$E_t = T \sum f_{v_i} P_{v_i} \Delta V \quad (5)$$

Equation (4) is a correction for the measured wind speeds. In this case the data for wind speed was taken with a reference of 10m, but the turbines would be at around a height of 20m,  $v_h$  is the wind speed at the height of the turbines,  $v_{h_r}$  is the wind speed at the reference height of 10 meters, while  $h$  and  $h_r$  are the height of the turbines and the reference height respectively.

Moreover, the expression in (5) is for the generation, where  $E_t$  is the generated energy in a  $t$  period of time,  $P_{v_i}$  is the power at each step of the turbines power curve and  $\Delta V$  is the differential between the previous and current step of the power curve for each iteration of the sum.

3) *Calculation of the available surface area for wind turbines:* As previously mentioned, the space allocated for the wind turbines is the western edge of the building as seen on Fig. 2. The turbines need to be spaced 4.5m from each other which leaves enough space in this ledge for 9 of these turbines. If an extra 4.5m is left between the turbines and the nearest solar panel installation, the total roof space needed for the turbines is 350.26 m<sup>2</sup>.

4) *Calculation of generation capacity:* The weather data used for the design was provided by Solargis(R), this dataset consists of hourly datapoints for various meteorological parameters, taking into consideration the period between January 1<sup>st</sup>, 1999, and December 31<sup>st</sup>, 2019. The dataset contains wind speed and direction data for every hour of the year, based on satellite measurements. The wind direction data was not used for these calculations since, as previously mentioned, the turbine used for the system is a vertical shaft model and does not have to be placed at a specific orientation, because wind blown from any direction will make the blades turn adequately.

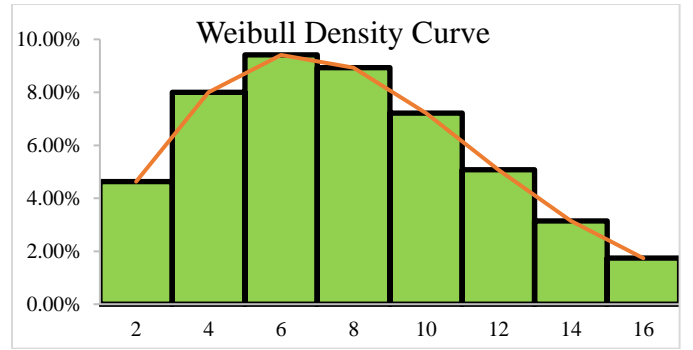

Fig. 3. Weibull density curve resulting from the chosen turbine and site data. Source: The authors

Fig. 3 shows the resulting Weibull density curve, created using results from (1)-(4). The results for generation in the month of March for the wind energy portion of the system is about 69,151.08 kWh.

### B. Solar energy system sizing

The process for solar sizing was comprised of the following steps:

1. Selection of the equipment
2. Sizing method
3. Calculation of available surface area for panels
4. Calculation of generation capacity

The steps were performed as follows:

1) *Selection of the equipment:* The panels ultimately selected for the study are the Sun Power SPR-A450-COM, which have a power output of 450 W, an efficiency of 22.2% and a module area of 2.03 m<sup>2</sup> [9]. These panels have one of the most efficient crystalline (m-SI) solar cells, paired with a high-power output which makes them the most efficient options right now [10].

2) *Selection of the sizing method:* There are many methods that can be used to evaluate the energy generated by photovoltaic modules in buildings. The method applied in this study was the installed power method (IPM) [11], which fits well with the plan to design the generation system based on available space rather than the demand of the building. To calculate the PV system's nominal power, the following equations are used:

$$P_i = NP_n \quad (6)$$

$$W_{el} = \frac{E_{daily}}{E_{STC}} k_{eff} P_i \eta \quad (7)$$

In (6)  $P_i$  is the installed power in kW,  $N$  is the number of modules, and  $P_n$  is the nominal power of the module in kW. For equation (7)  $W_{el}$  is the generated electricity in kWh d<sup>-1</sup>,  $E_{daily}$  is the daily solar irradiation on the module in kWh m<sup>-2</sup> d<sup>-1</sup>,  $E_{STC}$  is the solar irradiation for standard test conditions (1 kW m<sup>-2</sup>),  $k_{eff}$  is the system performance correction factor of 0.85, as recommended by [12], and  $\eta$  is the efficiency of the panels.

3) *Calculation of the available surface area for solar panels:* The remainder of the available roof space after taking the wind turbines into consideration is 3,521.86 m<sup>2</sup>. For this study the whole roof space was used, acknowledging that the actual area covered by panels in a physical installation will be less due to needs for spacing for maintenance, mounting platforms, among others. Taking this area and the 2.03 m<sup>2</sup> size of each module into consideration, the number of panels used in the model is 1,743.

4) *Calculation of generation capacity:* The monthly irradiation used in this generated energy is calculated using (6) and (7). First, the nominal power of the solar panels ( $P_n = 450$  W) is multiplied by the number of panels on the roof of the building (1,743) to calculate the installed power ( $P_i$ ). This results in an installed power of  $P_i = 784.35$  kW. Finally, the generated electricity during the month in question is estimated using (7) and the global monthly solar irradiation of 178.915 kWh m<sup>-2</sup> for March, taken from the same database used in the wind energy calculations. This results in a solar generation of 26,480.64 kWh, after correcting the generation with the 22.2% efficiency of the chosen solar panels.

### C. Battery bank sizing

The battery bank sizing is a simpler affair than both the wind and solar energy portions of the system. The batteries chosen were the Tesvolt TS25. These are highly efficient modular battery banks with a nominal operation voltage of 48V, a depth of discharge (DoD) of 100%. Each rack of these batteries can hold up to 10 individual 4.8 kWh batteries, which can easily be replaced if needed. For the actual capacity of the bank, a one-day generation storage capacity was chosen. The day of highest combined solar irradiation and average wind speed was chosen, with a priority on highest wind speed as from the previous calculations, is important to note that the turbines equate to more energy generation than the solar panels of this specific system.

Using the weather data from this day, March 7<sup>th</sup>, we get a combined generation of 6,678.77 kWh, which is taken as the required capacity for the battery bank. Since each individual battery tray can store 48kWh, the system will need 139 battery trays to store the energy generated in one day. It is worth mentioning once more that this design is purely theoretical and therefore does not take monetary parameters into consideration for its design.

### D. Building power demand

The energy demand of the building was calculated using the powerful dynamic simulation software Designbuilder with EnergyPlus. A complete model of the building was constructed, this model includes accurate measurements of every room and open space within the building, construction materials, air conditioning needs, historical climate data, and other parameters required for adequate and accurate

simulations. Fig. 4 shows a visualization of the building model in Designbuilder, with the sun position for March 7<sup>th</sup> at 3:00pm.

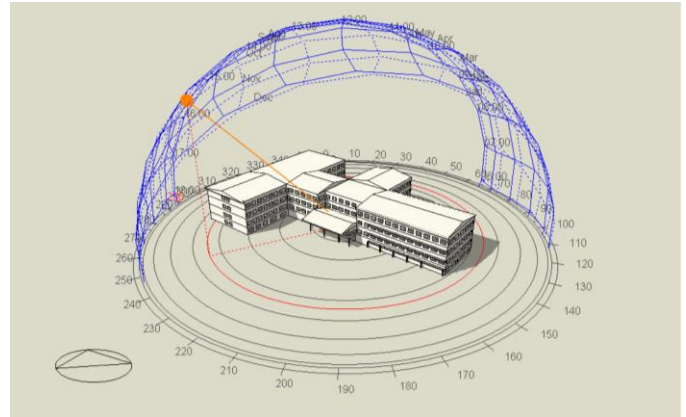

Fig. 4: Visualization of the buildings 3D model in Designbuilder.

Building #1 is a four-story tall structure which serves as a center for learning and administration, with classrooms, laboratories, administrative offices and two cafeterias. It holds four of the seven departments of the university: Civil Engineering, Electrical Engineering, Mechanical Engineering, and Industrial Engineering. This building had a total of 11,800 students for the second semester of 2022 [13]. Tables I and II contain the general construction details of the building and the details of energy use and operation hours respectively. All this data was input into Designbuilder for the simulations.

TABLE I  
CONSTRUCTION DETAILS OF BUILDING #1 OF THE TECHNOLOGICAL UNIVERSITY OF PANAMA\*

Component	Material	Heat transfer coefficient U (Wm <sup>-2</sup> K <sup>-1</sup> )
Walls (exterior and interior)	0.100m thick concrete blocks, with 0.015m thick double filling	1.94
Floors	0.040m x 0.040m porcelain tiles	2.98
Roof	0.038m thick sandwich style expanded polyurethane, over a metal structure	0.39
Ceiling	Suspended. 0.0508m x 0.0508m mineral fiber on aluminum tees, 2.700m above floor level	1.94
Doors	2.00m x 1.00m pine wood	1.11
Windows	Sliding. Gray tinting single glazing with 0.006m thickness	5.70

\*Data provided by the General Directorate of Engineering and Architecture (DGIA) of the Technological University of Panama.

TABLE II  
ENERGY USE AND OPERATION HOURS DETAILS

Equipment	Estimated consumption	Operating hours
Interior lighting (fluorescent bulbs)	32W	Mon-Fri 07:00-22:30
Consumption density by equipment	17.6 W/m <sup>2</sup>	Sat 8:00-18:00
Exterior lighting	100W	Mon-Sun 18:00-07:00
Air conditioning system (water-cooled chiller with fan coils)	30kWh/m <sup>2</sup>	Mon-Fri 07:00-22:30

After running the pertaining simulations, the following results showing energy needs of the building for the whole month are obtained:

TABLE III  
ENERGY DEMAND FOR MARCH

Room Electricity (kWh)	Lighting (kWh)	Cooling (Electricity) (kWh)	DHW (Electricity) (kWh)	Exterior lighting (kWh)
35,473.96	3,805.82	236,167.19	4,409.39	35.33
Total (kWh) 279,891.70				

And for a daily analysis, the results for just March 7<sup>th</sup>, for an easier comparison with the battery bank capacity:

TABLE IV  
ENERGY DEMAND FOR MARCH 7<sup>th</sup>

Room Electricity (kWh)	Lighting (kWh)	Cooling (Electricity) (kWh)	DHW (Electricity) (kWh)	Exterior lighting (kWh)
1,458.52	159.85	7,957.18	156.75	1.15
Total (kWh) 9733.45				

### III. RESULTS ANALYSIS AND DISCUSSION

The analysis and discussion will center around two main points:

1. What is the percentage of the buildings energy demand that the generation can fulfill?
2. Given the intermittent nature of the two renewable energy sources used in the design, is it possible to maintain energy availability all day long using the battery bank?

For the first point it is necessary to directly compare the results of the energy simulation with the sizing of the energy generation system, by a simple subtraction of the demand and the generation, we get the following:

TABLE V  
ENERGY DEMAND FULFILLMENT

Energy demand (kWh)	Wind generation (kWh)	Solar generation (kWh)	Leftover demand (kWh)
279,891.70	69,151.08	26,480.64	184,259.98

279,891.70	69,151.08	26,480.64	184,259.98
------------	-----------	-----------	------------

From Table V, we can gather that there is an outstanding 184,259.98 kWh (65.83%) of demand unfulfilled by the generation system, which means that the system can fulfill about 34.17% of the energy demand in March.

This is just a simple calculation, which leaves out a big part of the system, the battery bank. Thus, the second point arises, and for this, a closer analysis is required. Going back to March 7<sup>th</sup>, an hourly analysis of the system was done with EnergyPlus through Designbuilder, the results can be seen in Table IV.

TABLE VI  
SUMMARY OF HOURLY RENEWABLE ENERGY GENERATION AND BUILDING CONSUMPTION FOR MARCH 7.

Time	Solar generation (kWh)	Wind generation (kWh)	Building demand (kWh)	Demand fulfilled (%)
0:30	0	103.45	3.19	3242.95
1:30	0	103.14	2.99	3449.50
2:30	0	103.14	2.79	3696.77
3:30	0	103.42	2.66	3887.97
4:30	0	103.24	5.95	1735.13
5:30	0	99.57	104.42	95.36
6:30	8.67	97.69	78.42	135.63
7:30	1.92	92.17	496.34	18.96
8:30	57.87	78.68	555.57	24.58
9:30	87.03	73.90	658.79	24.43
10:30	98.72	72.74	685.69	25.01
11:30	137.50	73.90	721.10	29.32
12:30	143.57	75.08	715.41	30.56
13:30	135.87	75.08	715.29	29.49
14:30	120.62	73.90	751.29	25.89
15:30	87.77	75.08	759.65	21.44
16:30	58.76	86.08	742.21	19.51
17:30	25.31	100.42	657.27	19.13
18:30	2.07	101.18	584.77	17.66
19:30	0	101.18	471.67	21.45
20:30	0	102.43	410.17	24.97
21:30	0	103.45	357.09	28.97
22:30	0	103.42	247.70	41.75
23:30	0	103.42	3.03	3413.20

Subsequently, this information is plotted as presented in Fig. 5. As shown both on Table VI and the plot on Fig. 5, there is a big advantage of having a hybrid generation system. The hours that solar energy can be generated are limited, but

the wind turbines will keep generating energy as long as there's wind, no matter what time of day it is. While solar and wind energy generation is completely used up by the buildings demand during the daytime hours, outside of business hours the wind turbines keep generating energy that can be stored in the batteries for use during peak hours.

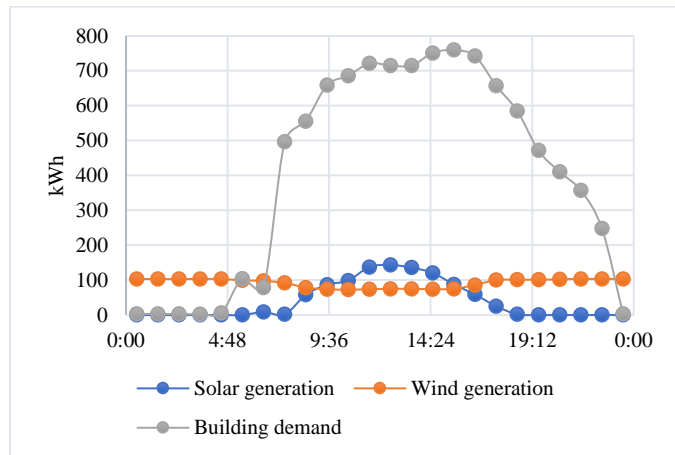

Fig. 5: Energy generation and Building demand for March 7.

However, it is plain to see from Fig. 5 that the energy generated by the wind turbines outside of business hours is not nearly enough to cover the energy demand of the building. Putting it into numbers, this energy surplus can be stored in the batteries amounts to 627.15 kWh. While not a significant amount for the building, it does mean an increase in overall efficiency of the system and allows the battery bank to be reduced from 139 battery trays to 13, being just enough to store this surplus, since during the daytime there is normally going to be no possibility of storing energy.

Moreover, looking at the values in Table V, it may be expected that renewable energy system could cover 95,631.72 kWh. However, it is critical to analyze the energy generation in an hourly period due to the highly instability nature of such renewable energy sources. As aforementioned, significant generation is obtained during the first hours of the day. This generation could be stored progressively, for instance, during the first days of each month to later exploit it.

Furthermore, regarding the economic investment and maintenance this renewable energy system requires, a life cycle cost analysis is necessary for comparing savings to investment, since the battery bank has the highest share. Alternatively, indirect energy storage can be implemented via thermal storage tanks with hot water, such as done in [14].

#### IV. CONCLUSIONS

Based on the findings of this research on the hybrid solar and wind energy generation system with a battery bank designed to supply energy to a building, the following conclusions can be drawn:

1. The hybrid solar and wind energy generation system with a battery bank can be an effective and sustainable solution for helping to meet the energy demands of a building. Specifically, to help reduce the base line consumption in peak demand hours.
2. The combination of solar and wind energy generation sources, along with the energy storage system, can enable a reliable and continuous energy supply to the building, especially since a hybrid system means that even if one energy source is unavailable, another one may be functioning adequately.
3. The performance of the hybrid energy generation system was found to be influenced by various factors, such as the capacity of the available space for installation of wind turbines and solar panels, and the geographical location of the building.
4. The energy supply from the hybrid solar and wind energy generation system in our study was able to meet about 34% of the building's energy demands for the selected month. This highlights the potential of this technology to significantly reduce reliance on energy from the grid.
5. The hybrid energy generation system can have positive economic and environmental impacts, including reduced energy costs, reduced greenhouse gas emissions, and increased energy independence for the building owner. However, this study did not take into consideration any monetary parameters, so further research that takes this into consideration is heavily encouraged.

In summary, our research highlights the feasibility and potential benefits of using a hybrid solar and wind energy generation system with a battery bank to supply energy to buildings. Further research can focus on assessing state-of-the-art technologies in wind and solar power, and the optimization of the energy management system to improve systems' efficiency and effectiveness in meeting energy demands. Finally, the university campus encompasses nine massive buildings, which with a proper energy management system and monitoring energy demand and production, could benefit from the renewable energy community concept application.

#### ACKNOWLEDGMENT

The authors would like to thank the Department of Mechanical Engineering at the Universidad Tecnológica de Panamá for their collaboration and continued support of the Master's program in Mechanical Engineering Sciences, funded by Secretaría Nacional de Ciencia, Tecnología e Innovación (SENACYT).

#### REFERENCES

- [1] A. Gilbert, M. D. Bazilian, and S. Gross, "THE EMERGING GLOBAL NATURAL GAS MARKET AND THE ENERGY CRISIS OF 2021-2022 EXECUTIVE SUMMARY."
- [2] S. E. Razavi *et al.*, "Impact of distributed generation on protection and voltage regulation of distribution systems: A review," *Renewable and Sustainable Energy Reviews*, vol. 105. Elsevier Ltd, pp. 157–167, May 01, 2019. doi: 10.1016/j.rser.2019.01.050.
- [3] A. M. Bouzid, J. M. Guerrero, A. Cheriti, M. Bouhamida, P. Sicard, and M. Benghanem, "A survey on control of electric power distributed generation systems for microgrid applications," *Renewable and Sustainable Energy Reviews*, vol. 44. Elsevier Ltd, pp. 751–766, 2015. doi: 10.1016/j.rser.2015.01.016.
- [4] R. Madriz-Vargas, A. Bruce, and M. Watt, "The future of Community Renewable Energy for electricity access in rural Central America," *Energy Res Soc Sci*, vol. 35, pp. 118–131, Jan. 2018, doi: 10.1016/j.erss.2017.10.015.
- [5] C. Washburn and M. Pablo-Romero, "Measures to promote renewable energies for electricity generation in Latin American countries," *Energy Policy*, vol. 128, pp. 212–222, May 2019, doi: 10.1016/j.enpol.2018.12.059.
- [6] Centro Nacional de Despacho, "Capacidad Instalada de la República de Panamá." <https://www.cnd.com.pa/index.php/estadisticas> (accessed Feb. 01, 2023).
- [7] Renova Wind, "Renova Wind EOS 1kW." <https://renovawind.com/en/solutions/business-solutions> (accessed Feb. 01, 2023).
- [8] M. Huaiquan Zhang, "WIND RESOURCE ASSESSMENT AND MICRO-SITING."
- [9] SunPower, "SunPower A Series Solar Panels," 2023, Accessed: Feb. 01, 2023. [Online]. Available: [https://es-media-prod.s3.amazonaws.com/media/components/panels/spec-sheets/SunPower\\_A-Series.pdf](https://es-media-prod.s3.amazonaws.com/media/components/panels/spec-sheets/SunPower_A-Series.pdf)
- [10] E. Sage, "Best Solar Panels in 2023," Sep. 2016. <https://news.energysage.com/best-solar-panels-complete-ranking/> (accessed Feb. 01, 2023).
- [11] E. L. Didoné, "Parametric study for net zero energy building strategies in Brazil considering semi-transparent PV windows," 2014.
- [12] C. Zomer, J. Urbanetz, and R. Rüter, "ON THE COMPROMISES BETWEEN FORM AND FUNCTION IN GRID-CONNECTED BUILDING-INTEGRATED PHOTOVOLTAICS (BIPV) AT LOW-LATITUDE SITES."
- [13] Universidad Tecnológica de Panamá, "MATRÍCULA, SEGÚN FACULTAD Y SEDE SEGUNDO SEMESTRE 2021 Vs 2022," 2022. <https://utp.ac.pa/sites/default/files/documentos/2023/pdf/utp-matricula-comparativa-2dosemestre-2021-2022.pdf> (accessed Feb. 01, 2023).
- [14] S. Perrella, R. Bruno, P. Bevilacqua, D. Cirone, and N. Arcuri, "Energy Evaluations of a New Plant Configuration for Solar-Assisted Heat Pumps in Cold Climates," *Sustainability*, vol. 15, no. 2, p. 1663, Jan. 2023, doi: 10.3390/su15021663.