

Modeling and Simulation of Gas Microturbine based Distributed Generation

Marcelo Gustavo Molina, PhD¹, and Clara Ximena Cáceres, Eng.²

¹Institute of Electrical Energy, Universidad Nacional de San Juan, CONICET, Argentina, mmolina@iee-unsjconicet.org

²Department of Chemical Engineering, Universidad Nacional de San Juan, Argentina, xcaceres@unsj.edu.ar

Abstract— *This paper discusses the modeling and dynamic performance of a gas microturbine used as a distributed generator (DG). The model is valid for transient studies and includes speed, temperature, and acceleration or fuel control. The microturbine system consists of a gas microturbine engine, a permanent magnet synchronous generator (PMSG), a three-phase rectifier bridge, and a three-phase voltage source inverter (VSI) for connecting to the electric distribution grid. The detailed modeling approach is accomplished by using Simscape Electrical of MATLAB/Simulink. Steady-state and transient performance analyses are carried out for validating the methodology applied and the components used.*

Keywords— *Distributed generation, Gas microturbine, Dynamic modeling, Control, Simulation.*

I. INTRODUCTION

In the last decades, distributed generation (DG), especially based on renewable energies, has become a very attractive technique of decentralized power generation for both users and the power grid. The inherent benefits of these small-scale generators come from the application of efficient, reliable, and low-polluting technologies [1, 2]. Among various DG sources, gas microturbine (GMT) generation systems are currently presented as very promising DG systems for their integration into modern power grids [3]. Microturbines are small and simple-cycle gas turbines of a few hundred kW with combined electrical energy and waste heat production. They are part of a general evolution in gas microturbine technology. This technology benefits from the micro gas turbine's advantages and the application of small-scale combined heat and power (CHP) [4].

Gas microturbine generation systems provide multiple benefits to the electricity grid and customers. Among the numerous benefits of the electric system, stand out the reduction of losses in transmission and distribution, power supply in remote areas, the release of power system reserve capacity, more efficient control of reactive power and voltage regulation, a decrease of investment requirements, reduction of failure index and increase in the power quality. For the users, benefits include the increase in the dependability and quality of the power, reduction of the number of interruptions, efficient use of energy, decrease of cost of energy (e.g. cost in peak hours), easiness of adaptation to the installation site conditions and decrease of polluting emissions [5].

Even though natural gas is the most effective fuel to increase efficiency and minimize emissions of the main pollutant from MTGs, which is nitrogen oxide (NOx), there is currently a

growing interest in using alternative fuels. A market niche where GMTs are being positioned as a very good option for distributed generation is through the use of biogas, produced especially by biodegradation reactions of organic matter in the absence of oxygen (anaerobic digestion) and with the interaction of different bacterial populations. In this way, biogas-fueled GMTs have emerged as an efficient, low-pollution renewable DG alternative [6].

The modeling of combustion microturbines based on linear models has proven to be appropriate only in certain cases. This situation has forced the development of new techniques for the analysis and design of gas microturbines with the aim of considering non-linear effects. Therefore, GMT modeling has received special attention in recent years with research devoted to the identification and analysis of nonlinear systems. With this objective, complex and non-linear models in continuous time have been found.

In this paper, the modeling and the dynamic performance of a gas microturbine used as a distributed generator are proposed. The model is valid for transient studies and includes speed, temperature, and acceleration or fuel control. The microturbine system consists of a gas microturbine engine, a permanent magnet synchronous generator (PMSG), a three-phase uncontrolled rectifier bridge, and a three-phase three-level voltage source inverter for connecting to the electric distribution grid. The detailed modeling approach is accomplished by using Simscape Electrical of MATLAB/Simulink. Steady-state and transient performance analyses are carried out for validating the methodology applied and the components used.

II. MODELING OF THE GAS MICROTURBINE SYSTEM

A gas microturbine system, as shown in Fig. 1, is made up of a gas combustion microturbine engine integrated with a synchronous generator that produces electrical power operating at high speeds. This internal combustion turbine fueled by gas is smaller in size and operates at a higher speed than conventional turbines. It is directly coupled with a multipole synchronous generator with a very fast dynamic response and high efficiency to produce electric power in a controllable way (on demand). Since the turbine operates at high speeds, it can normally exceed hundreds of thousands of rpm according to the manufacturer (normally in the range of 50.000 to 120.000 rpm); thus, generating electrical energy with a variable frequency ac three-phase voltage, which can exceed tens of kHz (in the order of 10.000 of Hz). The high-frequency electrical power is converted to dc voltage and then inverted back to low-frequency (50-60 Hz) ac voltage through a power electronic

Digital Object Identifier: (only for full papers, inserted by LACCEI).

ISSN, ISBN: (to be inserted by LACCEI).

DO NOT REMOVE

interface (aka power conditioning system). A step-up transformer can be used for connecting the system to the electric distribution grid when required. All parts are coordinated through a two-level hierarchical control system [7].

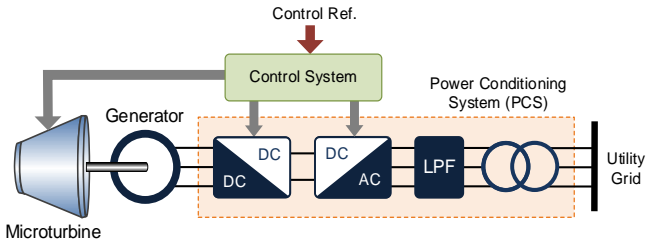

Fig. 1. General scheme of the microturbine global system.

The modeling of the gas microturbine system consists mainly of three parts: the gas microturbine engine, the permanent magnet synchronous generator, and the electronic power conditioning system (PCS).

The proposed model of the microturbine system is based on the following assumptions:

- The microturbine engine is similar to a conventional gas combustion turbine, but smaller in size and spinning at higher speeds.
- The microturbine system shares a single rotating shaft including the microturbine engine and the synchronous generator.
- Brushless permanent magnet synchronous generators (PMSG) are used in order to generate ac power.
- A power conditioning system is employed for connecting the microturbine to the utility grid.

A. Gas Microturbine Engine

Similar to a conventional combustion gas turbine, the microturbine engine mainly involves an air compression section, a burner or combustion chamber for the ignition of input fuel (gas), a recuperator of thermal energy from exhaust gasses for improving overall electrical efficiency, and a power microturbine driving a synchronous generator load, as depicted in Fig. 2. [8].

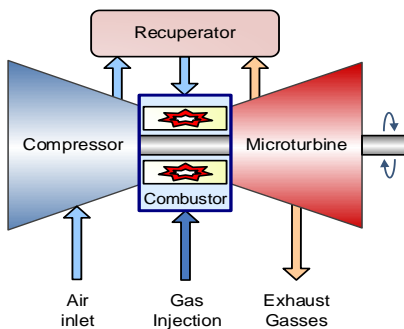

Fig. 2. Simplified scheme of a gas microturbine engine

Based on the previous considerations, the gas microturbine engine dynamics is modeled as a conventional gas turbine in

this work, as discussed in [7-9]. The model includes speed control, temperature control, and fuel control.

The microturbine engine's detailed dynamic modeling is carried out using Simscape Electrical of MATLAB/Simulink [10]. The microturbine engine general model including control system algorithms is shown in Fig. 3. Temperature of reference (T_{ref}), angular speed of reference (W_{ref}), and electromagnetic pair (T_e) are used as inputs in the full model.

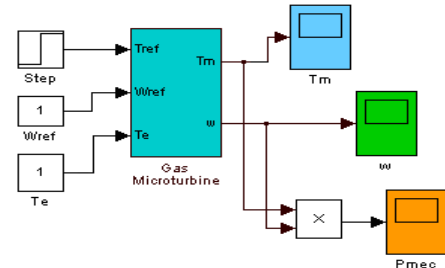

Fig. 3. General model of the gas microturbine engine implemented in MATLAB/Simulink.

The internal structure of the microturbine general model is shown in Fig. 4. It consists basically of three blocks: the gas microturbine itself and the control system consisting of a speed control or governor, and the temperature and fuel (gas) injection control (also known as acceleration control).

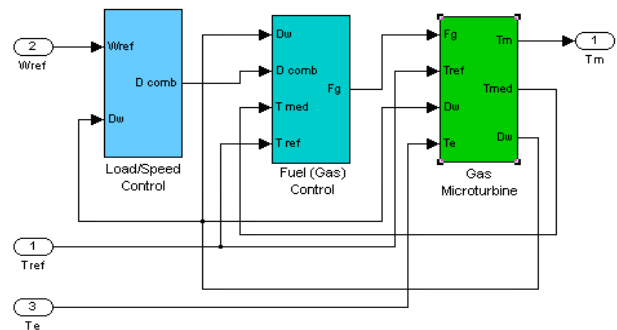

Fig. 4. Gas microturbine internal structure.

1) Speed/Load Control Gas Microturbine

The diagram of the speed/load control implemented in MATLAB/Simulink is portrayed in Figure 5. The signals for the speed governor are compared with the reference speed value and then incorporated into a proportional-integral (PI) controller block previously limited by the maximum and minimum values of the signal. The PI controller includes droop feedback in order to allow either droop or isochronous operation of the microturbine system, acting as a result as a first-order lag compensator.

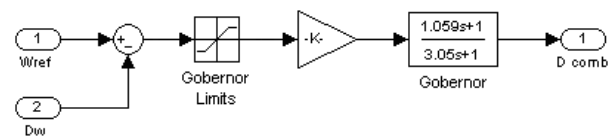

Fig. 5. Speed/load control implemented in MATLAB/Simulink.

2) Fuel Control or Gas Injection

The fuel control scheme (or gas injection control) is shown in Fig 6. The input signals consist of the fuel demand signal D_{comb} from the speed control, the measured exhaust temperature T_{med} from the gas microturbine, and the speed deviations D_w which is compared to the speed reference. The output signal of the model is the fuel flow F_g .

The measured exhaust temperature T_{med} is compared to T_{ref} so that the error acts on the temperature controller. Normally, T_{med} is lesser than T_{ref} causing the temperature controller to be at its maximum limit. In case T_{med} exceeds T_{ref} , then the controller will fall off the limit and goes to the point where its output takes over as the demand signal for fuel through the “low-value select” block [7]. This signal corresponds to the mechanical power in a steady state and is offset after being scaled by K_6 , which represents the fuel flow at no load. The output of the fuel systems is directly the fuel flow F_g .

3) Gas Microturbine

The gas microturbine block diagram is depicted in Fig. 7. The fuel flow F_g is burned in the combustor. The input signals to the gas microturbine are the fuel flow signal F_g from the prior gas injection control, the speed deviation D_w , the electromagnetic torque T_e and the reference temperature T_{ref} . The output signals are the mechanical torque T_m , the measured exhaust temperature T_{med} , and the speed deviation D_w . T_{med} is then feedbacked on the required inputs of other blocks [7].

B. Permanent Magnet Synchronous Generator (PMSG)

Electric power is generated by using a brushless permanent magnet synchronous generator which is coupled to the microturbine axis, as was previously depicted in Fig. 1. Essentially, a PMSG is similar in configuration to a conventional synchronous alternator with the electrical excitation system replaced by permanent magnets [2]. The benefits of using permanent magnets include the elimination of the brush/slip ring system. The output frequency of the ac voltage of the PMSG for microturbines is very high, up to

10 kHz. The generator also acts as a starting motor that allows the microturbine to start and put the unit into operation.

The equations describing the PMSG dynamic behavior in the rotor reference frame (dq frame) are stated below. The machine's electrical and mechanical parts are represented by a second-order state-space model.

Electrical system equations:

The electrical system makes use of a sinusoidal model, which assumes that the flux established by the permanent magnets in the stator is sinusoidal, implying sinusoidal electromotive forces.

$$\frac{d}{dt}i_d = \frac{1}{L_d}v_d - \frac{R}{L_d}i_d + \frac{L_q}{L_d}\omega_r i_q \quad (1)$$

$$\frac{d}{dt}i_q = \frac{1}{L_q}v_q - \frac{R}{L_q}i_q + \frac{L_d}{L_q}\omega_r i_d - \frac{\lambda\omega_d}{L_q} \quad (2)$$

$$T_e = \frac{3}{2}p[\phi_m i_q + (L_d - L_q)i_d i_q] \quad (3)$$

where:

L_q, L_d	q and d axis inductances
R	Resistance of the stator windings
i_q, i_d	q and d axis currents
v_q, v_d	q and d axis voltages
ω_r	Angular velocity of the rotor
λ	Amplitude of the flux induced by the permanent magnets of the rotor in the stator phases
p	Number of pole pairs
T_e	Electromagnetic torque

Mechanical system equations:

$$\frac{d}{dt}\omega_r = \frac{1}{J}(T_e - F\omega_r - T_m) \quad (4)$$

$$\frac{d\theta}{dt} = \omega_r \quad (5)$$

where:

J	Combined inertia of rotor and load
F	Combined viscous friction of rotor and load
θ	Rotor angular position
T_m	Shaft mechanical torque

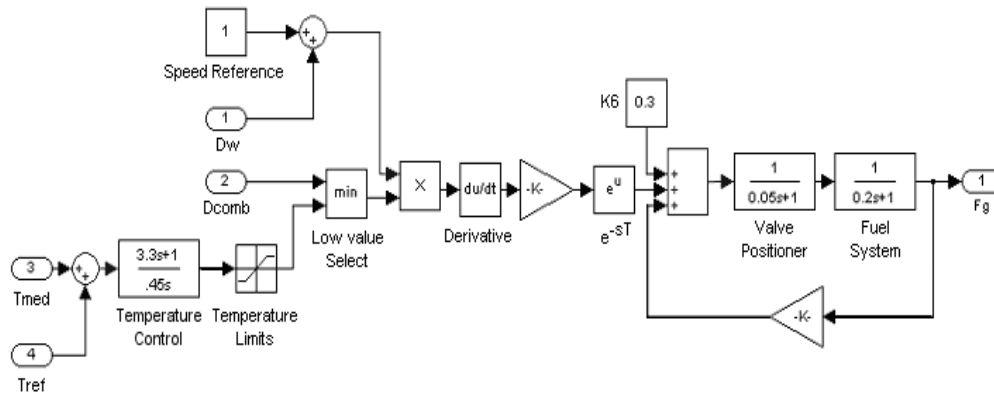

Fig. 6. Fuel (Gas injection) control system.

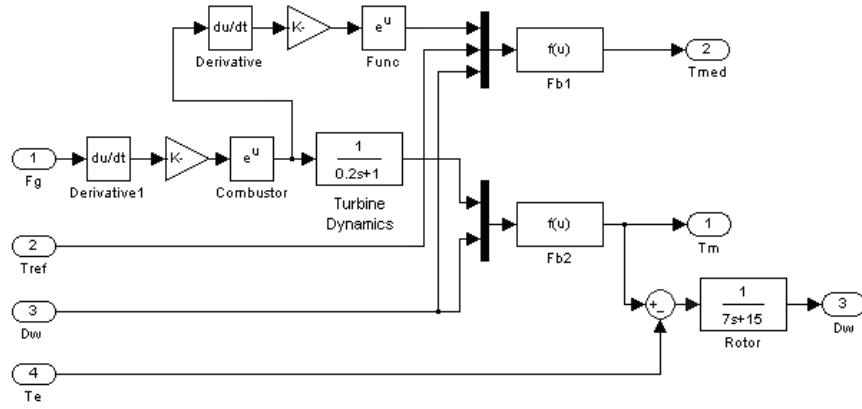

Fig. 7. Gas microturbine.

C. Power Conditioning System (PCS)

The power conditioning system (PCS) of the microturbine system is employed as the interface between the high-frequency PMSG (various kHz) and the low-frequency (50-60 Hz) utility distribution grid. This power electronic device consists mainly of two distinctive blocks, i.e., an uncontrolled three-phase diode-rectifier bridge, and a voltage source inverter including the dc bus capacitors, as shown in Fig. 8.

1) Three-phase Diode-rectifier Bridge

Since the microturbine rotates at high speeds, the ac power generated from the PMSG is at high-frequency. This feature demands using an ac-ac frequency converter. The first stage of this device is carried out by an uncontrolled three-phase diode-rectifier bridge which is simple, robust, and cheap. Besides, it does not require a control circuit. The output terminals of the rectifier are linked to a dc bus, which is also shared with a three-phase power inverter [11].

2) Three-phase Power Inverter

The conversion of dc power from the rectifier to ac power suitable for being connected to the utility grid is performed

through a power inverter. The proposed inverter corresponds to a dc-to-ac voltage source inverter (VSI) using Insulated Gate Bipolar Transistors (IGBTs) [12]. In the distribution voltage level, the switching device is generally the IGBT due to its lower switching losses and reduced size. In addition, the power rating of power devices is relatively low. As a result, the output voltage control of the VSI can be achieved through pulse width modulation (PWM) by using high-power fast-switched IGBTs.

The VSI structure is designed to make use of a three-level pole structure, also called neutral point clamped (NPC), instead of a standard two-level six-pulse inverter structure. This three-level inverter topology generates a more sinusoidal output voltage waveform than conventional structures without increasing the switching frequency. In this way, the harmonic performance of the inverter is improved, also obtaining better efficiency and reliability with respect to the conventional two-level inverter. A pair of capacitors are used as energy storage devices to interface both, the rectifier bridge and the power inverter. The connection of the inverter to the distribution utility system can be carried out through a coupling step-up transformer in order to meet the voltage level requirements when necessary.

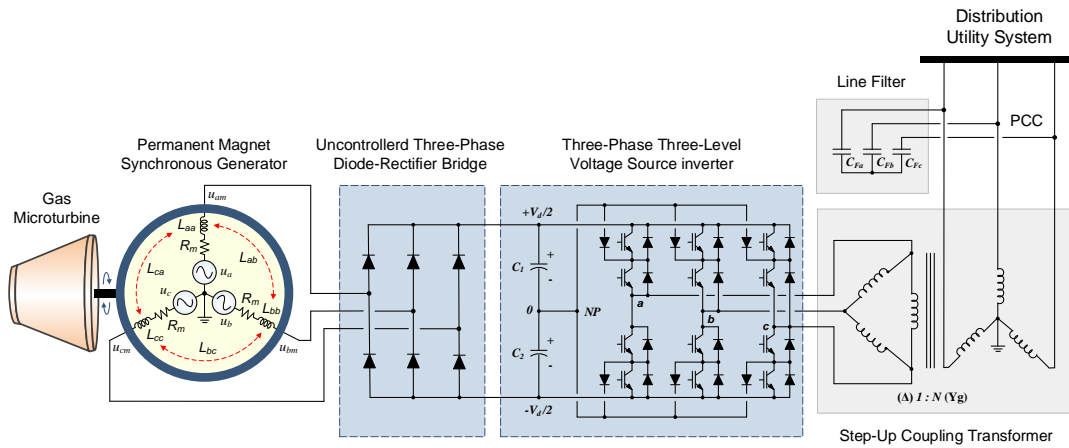

Fig. 8. Detailed model of proposed power conditioning system for microturbine for distributed generation.

3) Simplified Control of the PCS

Figure 9 illustrates the simplified control scheme of the microturbine power conditioning system. The main purpose of this controller is to transfer the active power generated by the microturbine into the utility grid. This objective is fulfilled by regulating the dc bus voltage V_d at a constant value via a proportional-integral (PI) controller, yielding a direct current reference i_{dr} to the VSI. This is achieved by forcing a small active power exchange with the electric grid for compensating the transformer winding and VSI IGBTs losses while exchanging ac power with the utility grid. A reactive power generation of the VSI is possible through a reference value of i_{qr} , which should be set at 0 when not required.

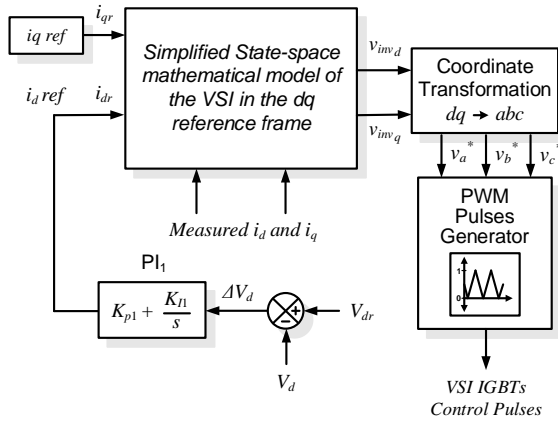

Fig. 9. Simplified control scheme of the microturbine PCS.

It is to be noted that a simplified stated-space model of the VSI in the dq frame, which is detailed in depth in [13, 14], is employed for generating the control pulses for the twelve switches of the VSI (IGBTs).

III. MODEL IMPLEMENTATION AND SIMULATION

In order to validate the proposed models and control schemes, a test system consisting of a gas microturbine system

connected to a distribution utility grid is simulated by using Simscape Electrical of MATLAB/Simulink, as shown in Fig. 10. Under this scenario, the 3 kV/5 MVA distribution utility is modeled as an infinite bus. The supply voltages and currents are balanced and in a steady state.

Digital simulations were carried out in discrete time with a fixed-step size of $25 \mu s$ as described in the following figures. The gas microturbine system was tested by forcing various operating conditions including changes in the grid and in the reference settings, such as a step change in a) electromagnetic torque or load T_e , b) reference angular speed W_{ref} , and c) reference temperature T_{ref} .

1) Step increase in the electromagnetic torque T_e

In this first case study, a 1 % increase in electromagnetic torque is applied at $t=3$ s. The simulation results for the mechanical torque, the rotor speed, and the mechanical power are shown in Fig. 11. As can be observed, the microturbine ramps up at about 2 s in order to balance the power variations that occurred after applying the disturbance. It is to be noted the fast dynamic response of the high-speed gas microturbine system.

2) Step increase in the reference angular speed W_{ref}

A 3 % increase in the reference angular speed is applied at $t=3$ s. The simulation results for the mechanical torque and the mechanical power are shown in Fig. 12. As can be examined, the microturbine ramps up at about 1 s in order to increase the mechanical torque and thus the power for reaching the new reference speed. As can be seen, the dynamic response of the microturbine system is faster than in the previous case, which applies a disturbance in the electromagnetic torque. This feature of higher sensibility to the disturbance is dependent on its point of entry. In the case of W_{ref} deviation, the perturbation is directly applied to the microturbine model while in the prior disturbance case, T_e is indirectly applied via the rotor dynamics which has a damping effect over the disturbance. In this way, the microturbine system is more robust to speed reference variations.

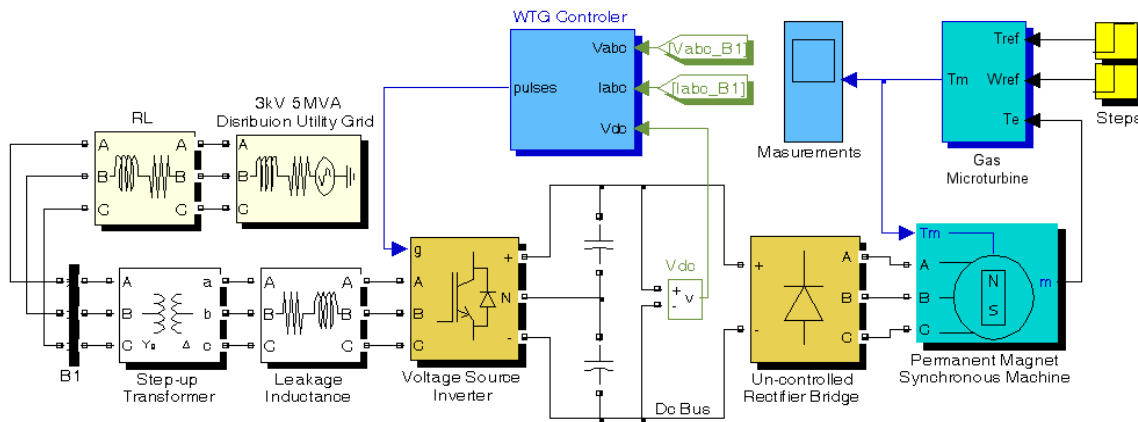

Fig. 10. Integrated implementation model of the gas microturbine for distributed generation applications.

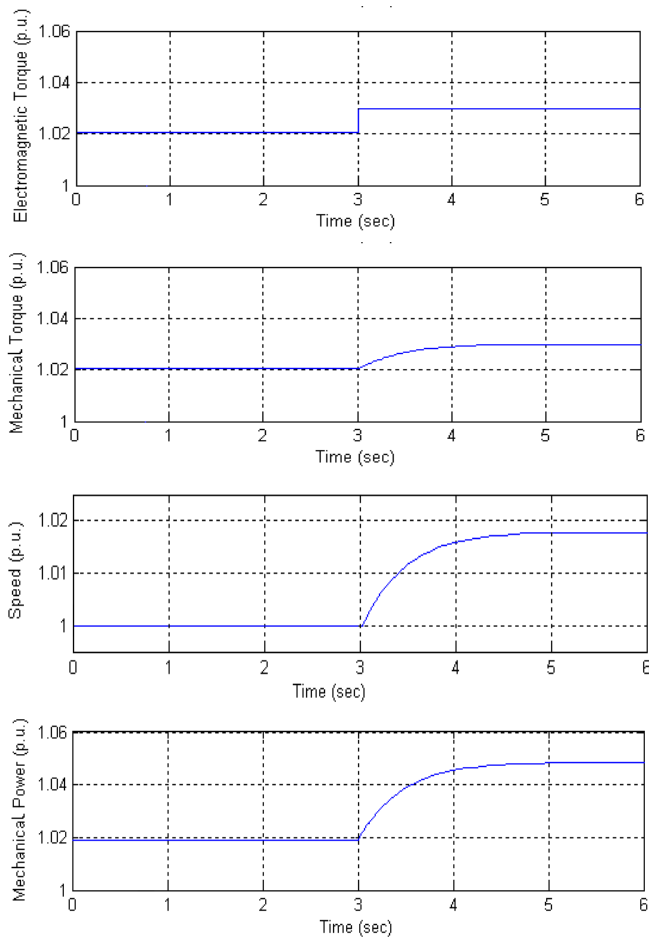

Fig. 11. Simulation results for a step increase in the electromagnetic torque T_e .

3) Step increase in the reference temperature T_{ref}

In this case, a 3 % increase in the reference temperature is applied at $t=3$ s (base temperature, 1000°C). The simulation results for the mechanical torque, the rotor speed, and the mechanical power are shown in Fig. 13. As can be noted, the reference temperature deviation is small enough to produce a noticeable effect over all variables shown, contrary to the disturbances of both previously presented cases. Much larger variations in the reference temperature are expected to influence the performance of the gas microturbine engine and thus both the electrical power/torque output and efficiency of the machine. In this way, the microturbine system is robust enough to reference temperature variations because of the action of temperature control.

Finally, Fig. 14 depicts the major electrical variables of the GMT system connected to the distribution system for a load dispatch of about 1.2 kW. As can be observed, the permanent magnet synchronous generator output rms voltage is about 180 V and the rated frequency reaches almost 760 Hz. In the same way, the PMSG output RMS current is around 7 A at the same rated frequency. The voltage at the dc bus of the three-level VSI, i.e. the rectified and filtered dc voltage from the PMSG ac output voltage, is effectively controlled by the

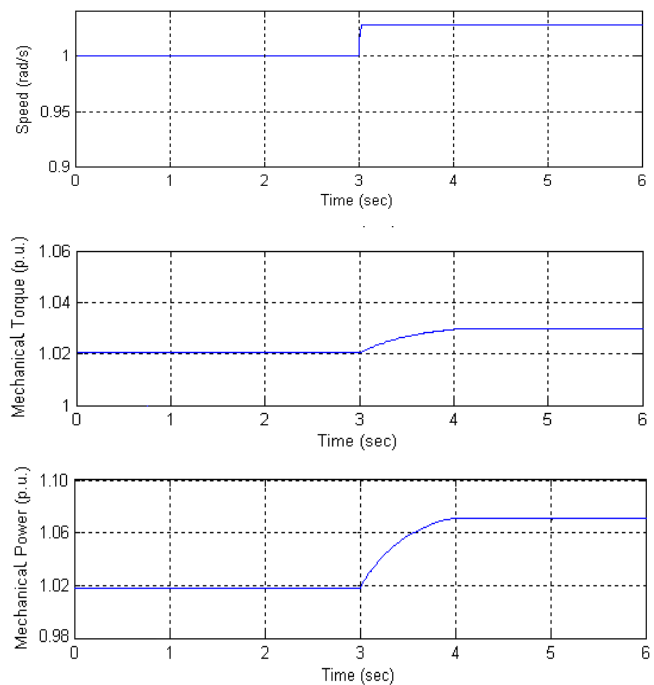

Fig. 12. Simulation results for a step increase in the reference angular speed W_{ref} .

inverter in order to be kept constant at a rated value of 200 V. In the output ac side of the microturbine global system, also called the point of common coupling (PCC) to the electric distribution grid, the voltage reaches about 3 kV rms via the step-up transformer (base voltage of 5.3 kV), and the frequency is converted to 50 Hz by the three-phase inverter.

IV. CONCLUSION

In this paper, a detailed model of a gas microturbine system for distributed generation applications is proposed. The model is developed by using the MATLAB/Simulink environment. Dynamics of each part comprising the gas microturbine system, i.e., the gas microturbine engine, the PMSG, the three-phase diode bridge, and the three-phase three-level VSI, are built by employing predefined models of Simscape Electrical and basic Simulink components of MATLAB. Simulation results permit concluding that the model proposed is adequate for both, steady-state and transient performance studies under different operating conditions. It can be used for analyzing the impact of incorporating combustion microturbines as distributed generators.

ACKNOWLEDGMENT

This work has been partially carried out thanks to the support of the Institute of Electrical Energy (IEE), the Department of Chemical Engineering (DIQ), the National University of San Juan (UNSJ), and the National Scientific and Technical Research Council (CONICET) of Argentina.

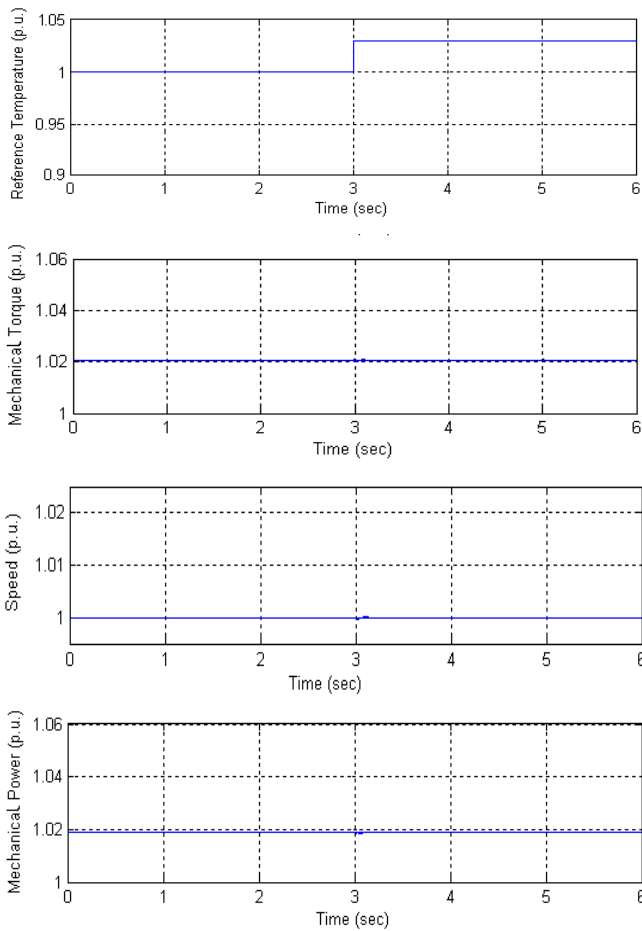

Fig. 13. Simulation results for a step increase in the temperature T_{ref} .

REFERENCES

- [1] M. G. Molina, "Energy storage and power electronics technologies: A Strong combination to empower the transformation to the smart grid," Proceedings of the IEEE, vol. 105, no. 11, pp. 2191-2219, Nov. 2017.
- [2] O. Zinaman, M. Miller, A. Adil, D. Arent, J. Cochran, R. Vora, S. Aggarwal, M. Bipath, C. Linvill, A. David, M. Futch, R. Kaufman, E. Villanueva-Arcos, J. M. Valenzuela, E. Martinot, D. Noll, M. Bazilian, and R. K. Pillai, "Power Systems of the Future," The Electricity Journal, vol. 28, no. 2, pp. 113-126, March 2015.
- [3] S. Abanades, H. Abbaspour, A. Ahmadi, B. Das, M. A. Ehyaci, F. Esmailion, M. El Haj Assad, T. Hajilounezhad, A. Hmida, M. A. Rosen, S. Safari, M. A. Shabi, J. L. Silveira, "A conceptual review of sustainable electrical power generation from biogas," Energy Science & Engineering, vol. 10, no. 2, pp.630-655, Feb. 2022.
- [4] S. L. Hamilton, Microturbine generator handbook, Tulsa, Oklahoma, USA, 1st Ed., PennWell, 2003.
- [5] M. A. Rosa do Nascimento, L. de Oliveira Rodrigues, E. C. Dos Santos, E. E. B. Gomes, F. G. Dias, E. I. G. Velásques, and R. A. Carrillo, "Micro gas turbine engine: A review," in Progress in Gas Turbine Performance, E. Benini, Ed., 1st Ed., London, U.K: IntechOpen, 2013, pp. 107-141.
- [6] C. X. Cáceres, R. E. Cáceres, D. Hein, M. G. Molina, and J. M. Pia, "Biogas production from grape pomace: Thermodynamic model of the process and dynamic model of the power generation system," Int. Journal of Hydrogen Energy, vol. 37, pp. 10111-10117, July 2012.
- [7] W. I. Rowen, "Simplified mathematical representations of heavy-duty gas turbines," Journal of Engineering for Power, vol. 105, no. 4, pp. 865-869. 1983.

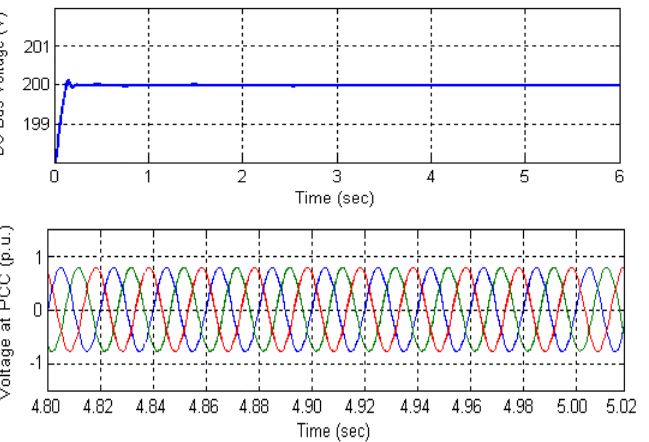
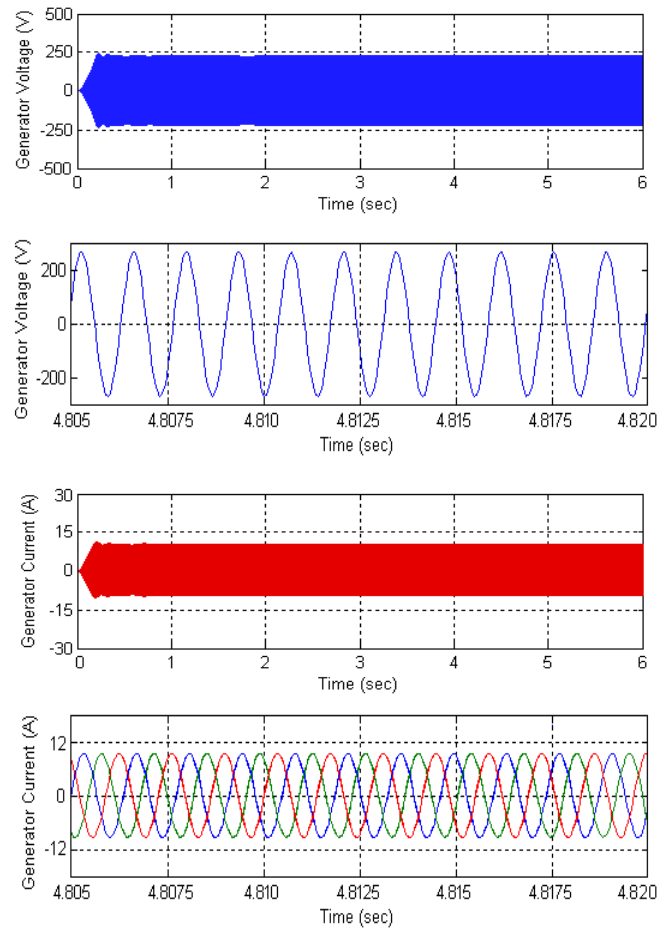

Fig. 14. Ac and dc voltages and currents of the GMT system dispatching 1,2 kW at the PCC to the distribution system.

- [8] H. Wei, Z. Jianhua, W. Ziping, and N. Ming, "Dynamic modelling and simulation of a Micro-turbine generation system in the microgrid," IEEE International Conference on Sustainable Energy Technologies, pp. 345-350, 2008
- [9] Y. Jin, J. Zhang, X. Wu, J. Shen, K. Y. Lee, "Coordinated control for combined heat and power load of an integrated energy system," IFAC Papers On Line, vol. 53, no. 2, pp. 13184-13189, 2020.

- [10] The MathWorks Inc, Simscape User's Guide, MATLAB and Simulink Release 2022b. [Online] Available in: <https://www.mathworks.com> [April, 2022].
- [11] M. G. Molina, "Grid Energy Storage Systems," in Power Electronics in Renewable Energy Systems and Smart Grid: Technology and Applications, B. K. Bose, Ed., 1st Ed. New Jersey, NJ, USA: Wiley-IEEE, June 2019, pp. 495-584.
- [12] J. I. Leon, S. Vazquez, L. García-Franquelo, "Multilevel converters: Control and modulation technique for their operation and industrial applications," Proceedings of the IEEE, vol. 105, no. 11, pp. 2066-2081, Nov. 2017.
- [13] M. G. Molina, and P. E. Mercado, "Renewable energy technologies for microgrids," in Microgrids design and implementation, A. Zambroni de Souza, M. Castilla, Ed., 1st Ed. Cham, Switzerland: Springer Verlag, 2018, Ch. 2, pp. 27-67..
- [14] M. G. Molina, Emerging Advanced Energy Storage Systems: Dynamic Modeling, Control and Simulation, Hauppauge, New York, USA, 1st Ed., Nova Science Pub., May 2013.